

Electric Multi-turn Actuator
Electric Part-turn Actuator
Electric Linear Actuator
Heavy-duty Pneumatic Actuator
Pneumatic Actuator
Pneumatic Actuator Accessories

HKC
Valve Automation

Valve automation leader **HKC**



HKC Co., Ltd.

Add. [Headquarter & Factory 1] 203, Gangchon-ro, Danwon-gu, Ansan-si, Gyeonggi-do, Republic of Korea (15427)
[Factory 2] 300, Sihwa venture-ro, Siheung-si, Gyeonggi-do, Republic of Korea (15117)

Tel. +82-31-488-8266

Fax. +82-31-488-8269 / 8696

E-mail. hkcon@hkcon.co.kr

Web. www.hkcon.co.kr

Published product features and data do not express warranty and may be subject to change without prior notice.

Electric Multi-turn Actuator
Electric Part-turn Actuator
Electric Linear Actuator
Heavy-duty Pneumatic Actuator
Pneumatic Actuator
Pneumatic Actuator Accessories



Product Catalog

Valve automation solutions come with HKC



Valve automation leader **HKC**

HCAG-OV-23 Rev.1 E

Company Introduction

Since 1991, HKC has been dedicated to delivering the highest quality products and services to our customers. Furthermore, we have made significant efforts to lead and advance the rapidly changing industry through continuous innovation management, technical development, human resource management, and more.

With a strong foundation in technical theory and diverse experience, HKC possesses unique know-how that serves as the driving force behind the development and scientific production of all our products. As a result, HKC is evolving into a first-class corporation that leads the valve automation industry with cutting-edge technologies.

HKC places great importance on corporate social responsibility. We actively seek opportunities for mutual progress, sharing, and development with our partners and customers. Moreover, our customer-focused management approach ensures that all our services prioritize customer satisfaction above all else.

HKC will continue to strive to become a global leading corporation in the valve automation industry of the 21st century. We aim to achieve this by making significant contributions to the future through the provision of the highest quality products, continuous development of new technologies, and unwavering customer service.



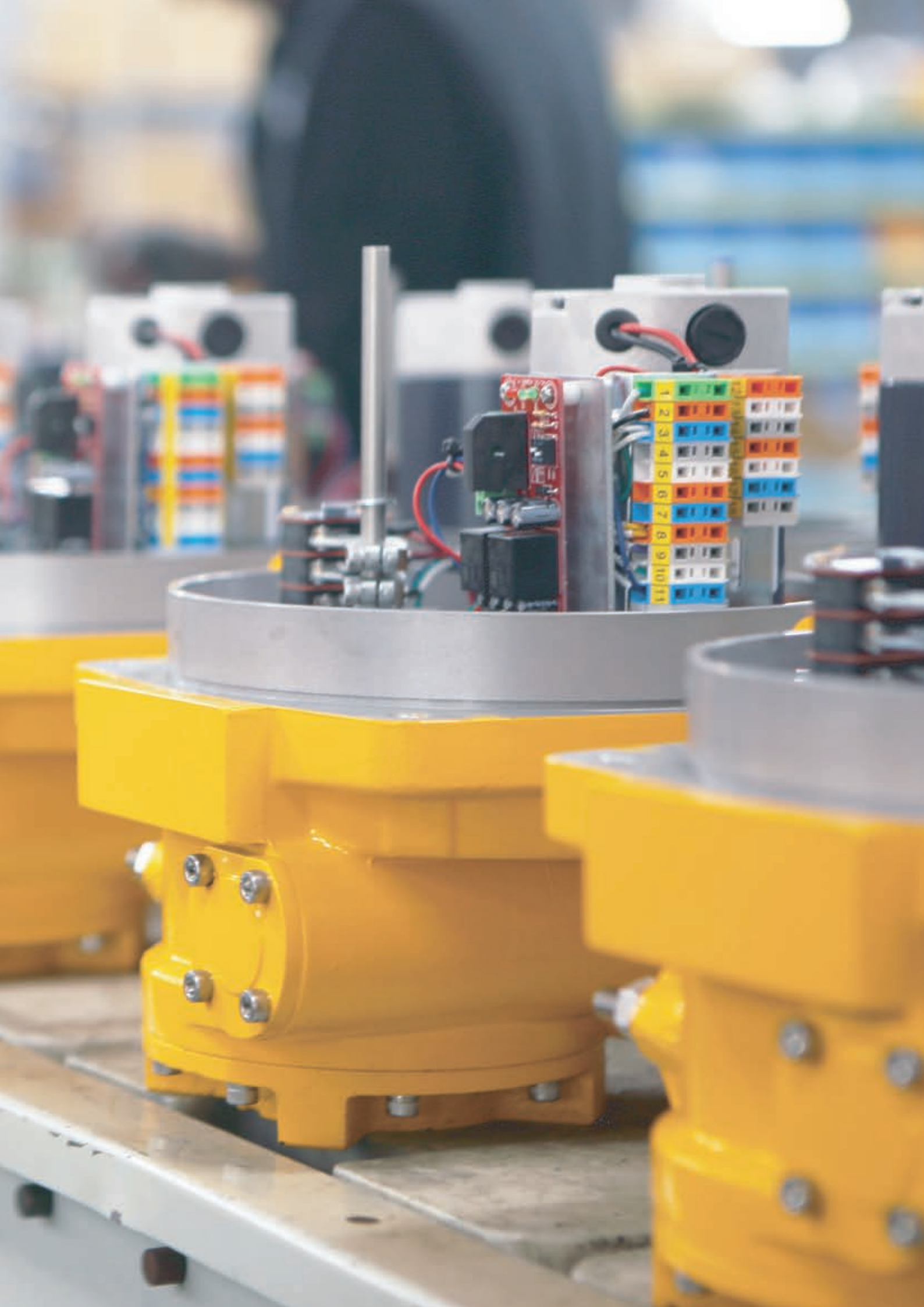



Contents

01

HM Series

Electric
multi-turn
actuator



10

HL Series

Electric
linear
actuator



17

HQ Series

Electric
part-turn
actuator



37

ET Series

Heavy-duty
pneumatic
actuator





46

HP Series

Pneumatic actuator



57

APL Series

Valve position monitor
limit switch box



71

HGO Series

Declutchable
gear override



Electric Multi-turn Actuator HM Series

Features

- A wide LCD window provides various useful information such as valve position and torque.
- Easy setup using a remote control
- Partial stroke function for valve diagnosis and water hammer prevention function are included as standard.
- Precise modulation control (500:1 based on 1 minute operating time) as an option
- Flameproof (Ex db IIB +H2 T4) as an option
- IP68 (upto 10 m, 72 hours) as an option
- Communication (PROFIBUS, MODBUS) options

Description

Providing safe and reliable operation, the HM Series electric multi-turn actuator is designed for all multi-turn valve applications, such as globe valve, gate valve, and etc. In combination with a gearbox, It is also used for large size quarter-turn valves, such as ball and butterfly valves.

Wide range of application

With reliable and stable operation, the HM Series is used in many industries:

- Oil & gas
- Power plant
- Chemical & petrochemical
- Water
- Marine & shipbuilding

High corrosion protection

The housings of all HM Series actuator are made from high grade aluminum alloys which are robust and light weight. To provide high corrosion resistance, the housings are hard-anoized on the inside & outside and epoxy-polyurethane coating is further applied on the outside. For usage in severe corrosive environments, nano-coating could be applied to the HM Series to enhance corrosion protection.

Wide range of torque

The direct torque of HM Series ranges from 35 to 3,000 Nm, and upto 500,000 Nm when combined with a worm gearbox.





User friendly interface

To set the HM Series actuator, there is no need to remove the cover (non-intrusive setting). All settings can be done by either using the local control switches or the remote control through the LCD window. The user interface supports English and Korean and displays:

- Current status display (open/ close/ stop)
- Current valve position & valve torque
- LED signal lamp
(Red: open/ green: close/ yellow: fault)
- Temperature
- Fault message
- System back-up rechargeable battery level

Smart and intelligent control

Motor overheat protection: the thermostat resistor inside the motor senses the temperature and stops the actuator in case of a motor overheat.

Precise modulation control: solid state design HM series actuators provide more accurate modulation control (500:1 based on 1 minute operating time).

Reversal protection: an auto time delay is added when the actuator is commanded to suddenly reverse its direction to prevent the valve from receiving a shock load.

Water hammer protection: adjustable pulsed operation is applied to any portion of the open/closing valve stroke to reduce the speed and to prevent the valve from receiving a hydraulic shock.

Partial stroke function: to ensure reliable valve operation, the HM-series partially opens/closes valve to the pre-set stroke and determines whether the valve is jammed or not.

Auto phase discriminator for 3-phase power

Password setting for security

Communication: PROFIBUS and MODBUS

Certificates and approvals

- IECEx (Ex db IIB +H2 T4 Gb)
- ATEX (II 2G Ex db IIB +H2 T4 Gb)
- KCs (Ex d IIB +H2 T4)
- EAC (1 Ex db IIB T4 Gb X)
- CCC (Ex db IIB +H2 T4 Gb)
- ABS type approval
- RMRS type approval

IECEX CE₀₃₄₄ Ex G EAC CCC ABS



Design Features

1 Body & cover: Body and cover of HM Series are made from high grade aluminium alloys. To have high corrosion resistance, they are hard anodized and epoxy-polyurethane coated. For usage in severe corrosive environments, nano-coating could be further applied to the HM Series to enhance corrosion protection. All components are precisely machined between the maximum and minimum permissible limits at HKC's machining center. The standard dimension of HM Series actuator is shown on page 9.

2 Motor: Available in 1-phase and 3-phase. The HM Series motors are customly built suitable for valve automation that have high torque, low current, and low inertia. Thermostat protection is ensured by a thermostat resistor inside the motor, which stops the motor in the event of an overheat.

3 Nameplate: All necessary information regarding the HM Series actuator can be found in the name plate such as model name, serial number, speed (in rpm), maximum torque, power, and etc. All HM Series actuators are assigned with a distinct serial number which is recorded in our system along with all necessary information for future reference.

4 Cable entries: HM Series actuators have 5 cable entries:

- Standard: 4 x PF1", 1 x PF1½" (HM-004 to 060)
4 x NPT1", 1 x NPT½" (HM-004 to 300)
- Flameproof: 4 x NPT1", 1 x NPT1½"

5 Terminal compartment: The double-sealed terminal compartment provides the actuator a complete protection from the environment even when the cover is removed for a wiring purpose, leaving the internal parts and wires intact.

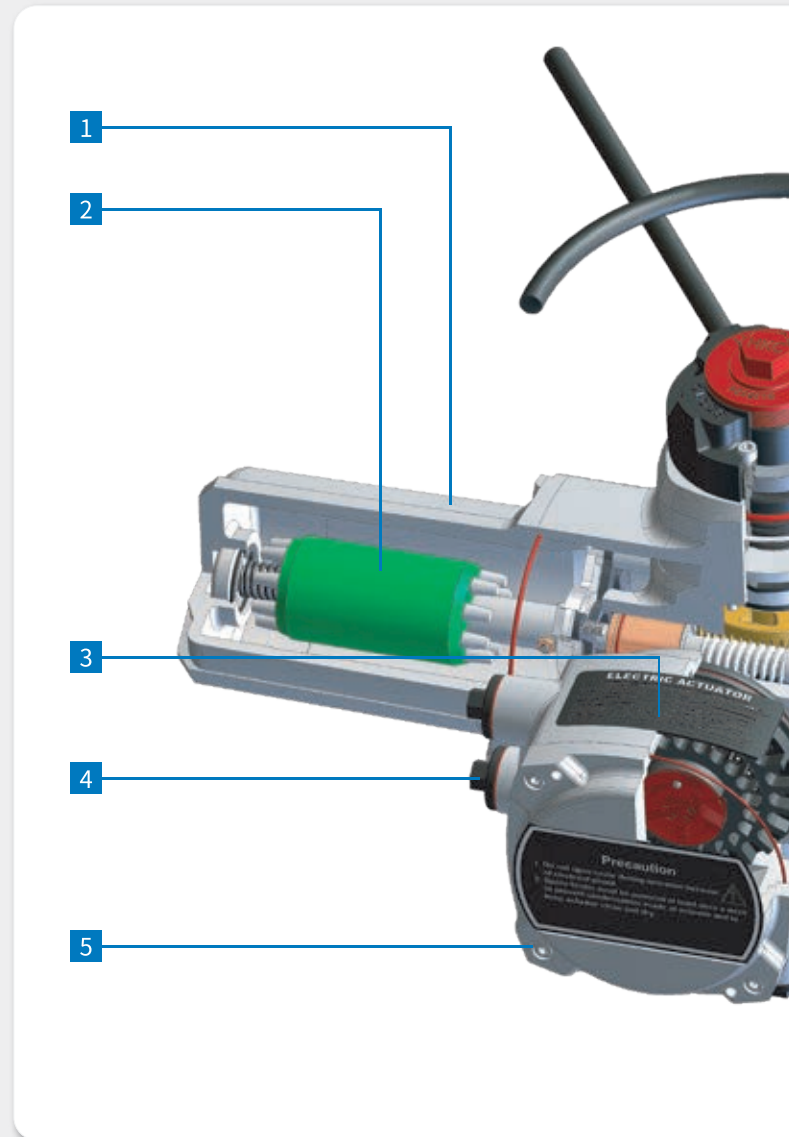

6 Handwheel: Manual operation (handwheel drive) can be activated when the **7 manual override lever** is locked into the manual operation (pushed down). Manual operation is independent of the motor drive thus it provides a safe operation; that is, the manual override lever can be pushed down and locked regardless of the motor status; whether the motor is running or not. Note that motor drive has preference over handwheel drive, which means the lever automatically returns when the motor starts running. Both handwheel and lever are designed to be easily separated from the body for easy maintenance and for convenient installation in narrow or small sites.

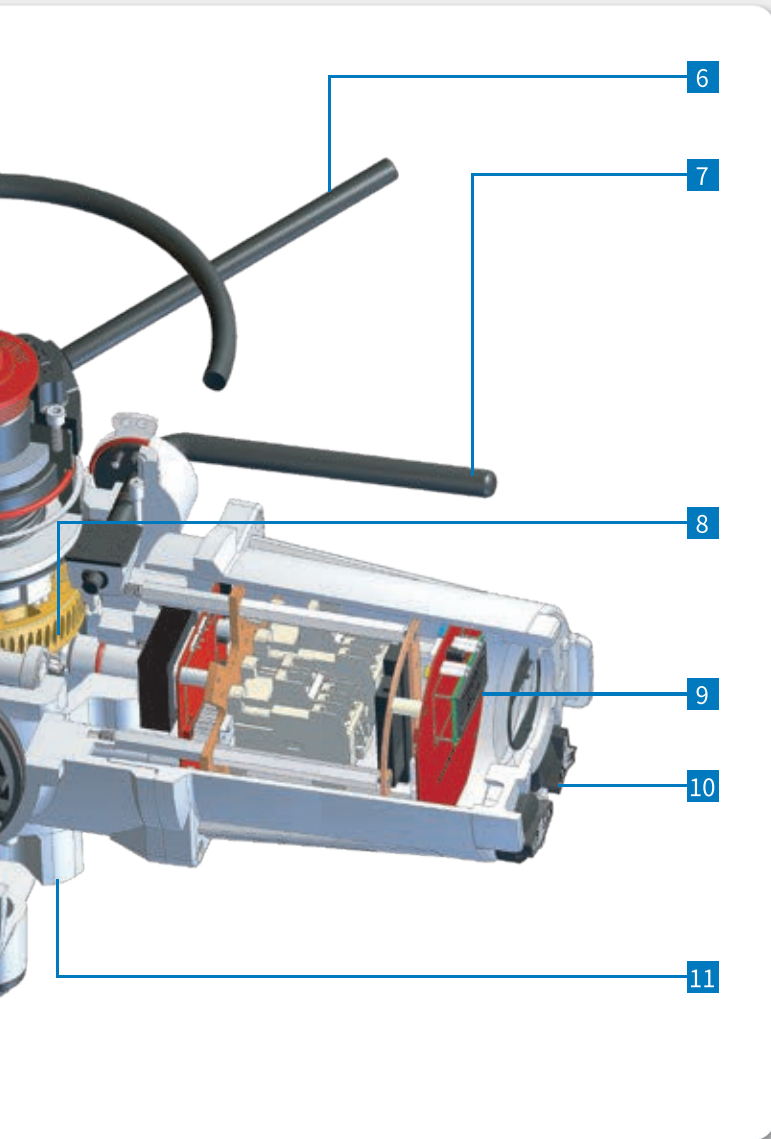

8 Worm gear system: The HM Series mechanical worm gear system provides a necessary self-locking feature which prevents displacement of valve position when an unwanted external force acts upon the valve.

9 Display: High resolution LCD screen displays various useful information including current status (open/ close/ stop), valve position, torque measurement, temperature, fault message, system back-up rechargeable battery level, and etc., along with duplicated LED signal lamp unit (red: open/ green: close/ yellow: fault). The display is protected by a thick 10 mm polycarbonate window.

All settings can be done by either using the local control switches or the remote control through the LCD window. The user interface supports English and Korean.

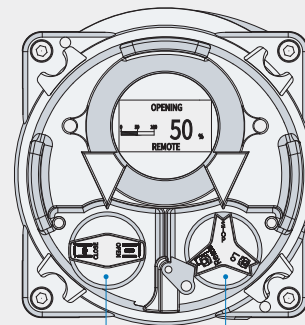

Function Selector Switch (Spring Return Type)

Operation Selector Switch

The standard handwheel for HM Series actuator is direct drive handwheel. For an effective and efficient manual operation, the size of the handwheel is selected in consideration of the actuator size.

Optional GearBox Handwheel (GBH) is also available on request which helps the user to turn the handwheel easier, but the number of turns increases by the gear ratio (please see Mechanical Data on page 9 for more details).

10 Local control switches: Both function selector switch (open/ close) and lockable operation selector switch (local/ stop/ remote) are magnetic switches that do not penetrate the control cover. This non-penetration design ensures isolation of the internal circuits and enhances the actuator protection from the environment such as water or dust ingress.

11 Mounting base: All thrust (ISO 5210) and non-thrust type (ISO 5211 or MSS SP102) bases can be easily separated for installation and maintenance. Meanwhile the actuator is still protected by the remaining bottom cover.

Torque Data

3-Phase Power

RPM		Torque (Nm)									
50 Hz	60 Hz	HM-004	HM-008	HM-011	HM-020	HM-040	HM-060	HM-100	HM-150	HM-200	HM-300
18	21	35	80	110	200	400	-	-	-	-	-
24	29	35	80	110	200	400	600	1,000	1,500	2,000	3,000
36	43	35	80	-	200	300	-	850	-	-	-
48	57	35	68	110	200	250	470	680	1,000	1,360	-
72	86	35	48	-	176	250	470	680	1,000	1,360	-
96	115	35	40	-	142	230	370	540	750	1,000	-
Motor rating (kW)		0.75	0.75	0.75	1.2	1.2	1.9	2.6	3.7	5.5	5.5

1-Phase Power

RPM		Torque (Nm)		
50 Hz	60 Hz	HM-008	HM-020	HM-040
18	21	65	165	450
24	29	60	130	400
36	43	45	130	350
48	57	40	125	320
72	86	30	100	230
96	115	25	80	190
Motor rating (kW)		0.75	1.2	1.2

Notes:

- HM-040 actuator requires 220 V ac or more.

3-Phase Power Solid State Design Model

RPM		Torque (Nm)									
50 Hz	60 Hz	HM-004	HM-008	HM-011	HM-020	HM-040	HM-060	HM-100	HM-150	HM-200	HM-300
18	21	35	80	110	200	400	-	-	-	-	-
24	29	35	80	110	200	400	600	1,000	1,500	2,000	3,000
36	43	35	80	-	200	300	-	850	-	-	-
48	57	35	68	110	200	250	470	680	1,000	1,360	-
72	86	35	48	-	176	250	470	680	1,000	1,360	-
96	115	35	40	-	142	230	370	540	750	1,000	-
Motor rating (kW)		0.75	0.75	0.75	1.2	1.2	1.9	2.6	3.7	5.5	5.5

1-Phase Power Solid State Design Model

RPM		Torque (Nm)	
50 Hz	60 Hz	HM-008	HM-020
18	21	65	165
24	29	60	130
36	43	45	130
48	57	40	125
72	86	30	100
96	115	25	80
Motor rating (kW)		0.75	1.2

Notes:

- HM-008 S1 actuator requires 110/220 V ac
- HM-020 S1 actuator requires 220 V ac

Specification & Mechanical Data

Standard Specification

Enclosure	Weatherproof enclosure IP67		
	High grade aluminium alloy, hard anodized & epoxy-polyurethane coated (HM-004 to HM-060)		
	Nodular cast iron & high grade aluminium alloy, hard anodized & epoxy-polyurethane coated (HM-100 to HM-300)		
Power supply	1-Phase: 110/220 V ac, 50/60 Hz, (HM-008, 020, 040) *HM-040 requires 220 V ac or more		
	3-Phase: 220/380/420/440/460/480-600 V ac, 50/60 Hz		
Voltage tolerance	±10%	Starting voltage drop (Max.)	-15%
Duty cycle (on-off)	1-phase power: S2 15 min, 3-phase power: S2 30 min (room temperature, average load of 50% of maximum torque)		
Torque	1-phase power: 24 to 450 Nm, 3-phase power: 35 to 3,000 Nm. When combined with a gearbox up to 500,000 Nm		
Ambient temperature	-20 to +70 °C	Monitoring switches	4-SPST, 250 V ac 16 A rating
Travel angle	0 to 10,000,000 turns	Cable entries	4 x PF1", 1 x PF1½" (HM-004 to 060) or 4 x NPT1", 1 x NPT1½" (HM-004 to 300)
Signal lamp unit	Red: open, green: close, yellow: fault	Indicator	Digital display position indicator
Self locking	By worm gear	Lubrication	Grease moly (EP type)
Motor	Induction motor (reversible motor)	Manual operation	Dec clutchable manual override
Designed life	Torque & thrust test: 50,000 cycles		
Mounting base	Multi-turn: ISO 5210, Part-turn: ISO 5211 MSS SP-102		
Local/remote control	Local control: two rotary selector switches (function switch & operation switch), remote control: setting tool (LCD window)		
Coating (color)	● Grey (Munsell N6.5), ● Matte grey (Munsell M2.5)		

Optional Specification

Enclosure	EXD flameproof enclosure: Ex db IIB T4, Ex db IIB +H2 T4 (HM-004 to HM-060) (ambient temperature: -20 to +60 °C, cable entries: 4 x NPT1", 1 x NPT1½")		
	WTA Watertight enclosure: IP68 (10 m 72 hr)		
Additional switch	AMS Additional Monitoring Switches: 8, 12, 16 switches (SPST, 250 V ac 16 A rating)		
Ambient temperature	LT Low temperature: -60 to +60 °C (EAC), lubrication: tribolube-18		
Control	PCU Proportional control unit (modulating): input/output: 0-10 V dc or 4-20 mA dc, (duty cycle) 1-phase power: S4 25%, 3-phase power: S4 35%, 60-200 starts/hour (room temperature, average load of 50% of maximum torque)		
	CPT Current position transmitter (output: 4-20 mA dc)		
	PROFI Registered PROFIBUS DP interface modules		
Local control	MODBUS Modbus modules		
	ICM Independent Control Module to operate from a long distance		
Manual operation	ACS Actuator body and control unit separated		
Manual operation	GBH Gearbox Handwheel		
Coating (color)	● Other colors, ○ Nano coating (for corrosive environment)		
Others	FPA Fire Proofing Actuator (1050±5 °C / 50 min)/(250±5 °C / 150 min)		

Mechanical Data

Model	HM-004	HM-008	HM-011	HM-020	HM-040	HM-060	HM-100	HM-150	HM-200	HM-300
Flange size (ISO)	F10	F10	F10	F14	F14	F16	F25	F25	F30	F30
Weight (kg)	40	40	40	65	65	75	190	190	200	200
Thrust rating (Nm)	44	44	44	100	100	150	220	220	334	445
Hand wheel ratio	Direct	Direct	Direct	Direct	Direct	Direct	Direct	18:1	18:1	18:1
GBH ratio	15:1	15:1	15:1	15:1	15:1	23:1	54:1	54:1	54:1	54:1

Maximum Stem Diameter - Base

Model	HM-004	HM-008	HM-011	HM-020	HM-040	HM-060	HM-100	HM-150	HM-200	HM-300
Thrust	Rising	32	32	32	38	38	54	64	70	83
	Non-ris-	26	26	26	32	32	45	51	57	73
Non-Thrust	Large	42	42	42	60	60	80	100	120	120
	ISO type	20	20	20	30	30	40	50	50	N/A
	Blank type	20	20	20	30	30	44	50	60	N/A

Dimensional Drawing

HM-004 to HM-060

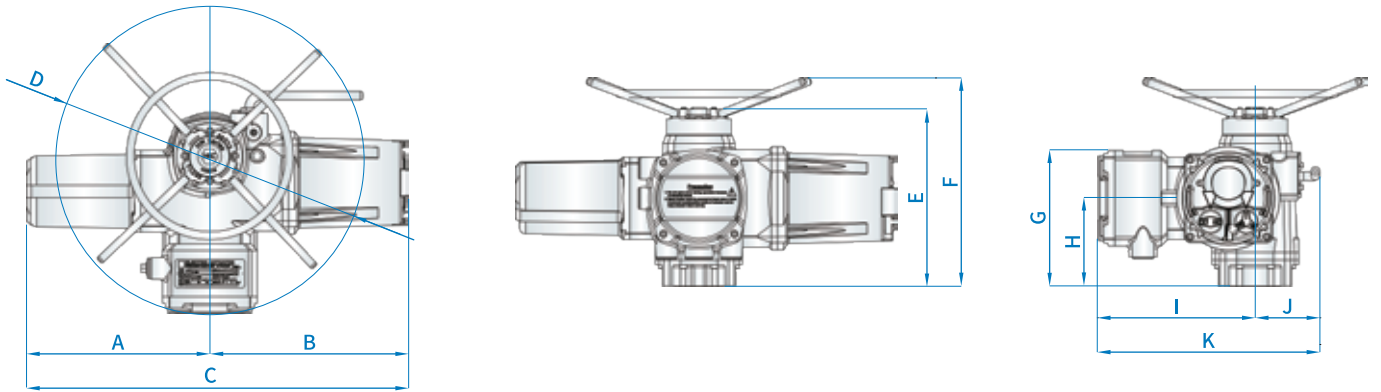

HM-100 to HM-300

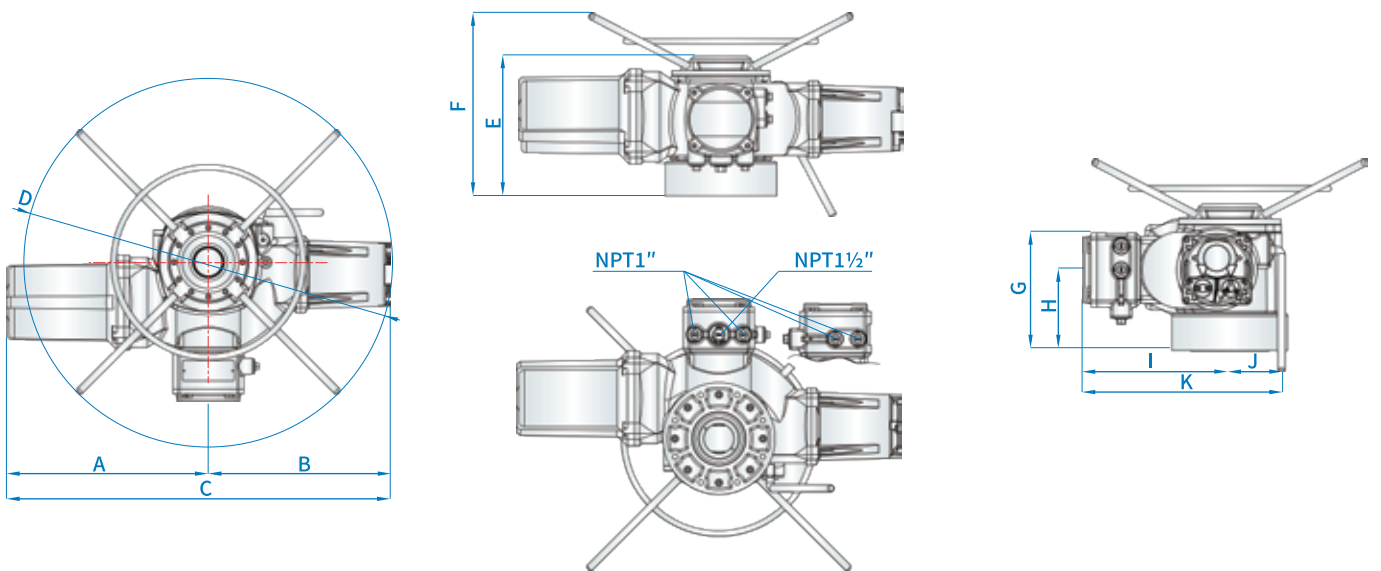

Dimension

unit (mm)

Model	A	B	C	D	E	F	G	H	I	J	K
HM-004	291	382	673	490	265	316	227	131	277	130	407
HM-008	291	382	673	490	265	316	227	131	277	130	407
HM-011	291	382	673	490	265	316	227	131	277	130	407
HM-020	369	400	769	620	357	420	274	178	318	130	448
HM-040	369	400	769	620	357	420	274	178	318	130	448
HM-060	384	407	791	835	393	481	294	198	320	132	452
HM-100	453	490	942	995	379	494	305	209	379	143	552
HM-150	453	490	942	995	379	494	305	209	379	143	552
HM-200	508	490	997	995	419	611	305	209	379	143	552
HM-300	508	490	997	995	419	611	305	209	379	143	552

Gearbox Handwheel GBH: HM-004 to HM-060

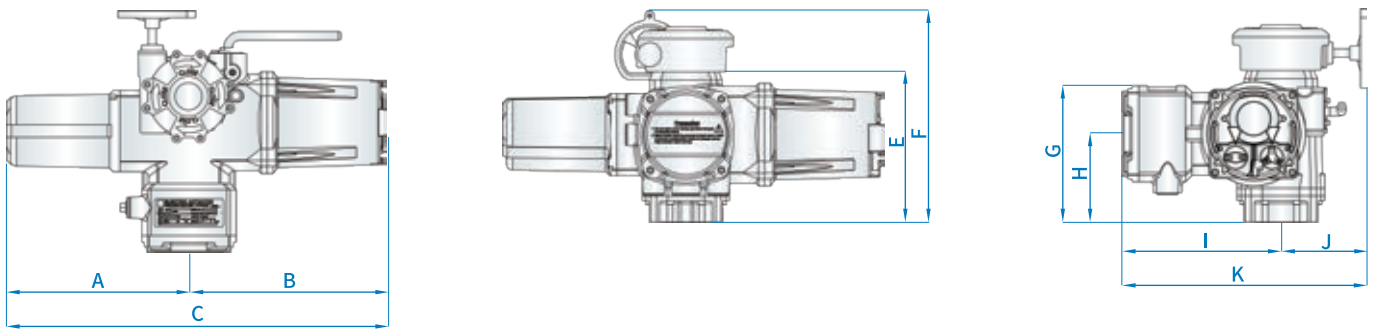

Gearbox Handwheel GBH: HM-100 to HM-300

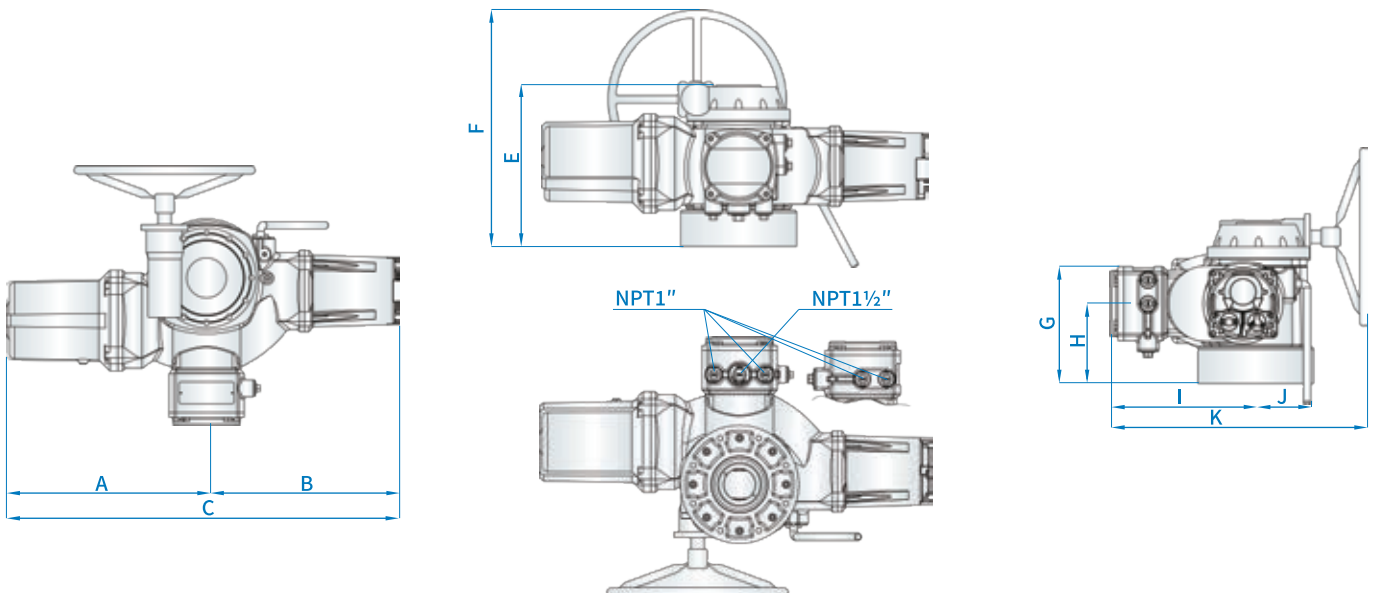

Dimension

unit (mm)

Model	A	B	C	E	F	G	H	I	J	K
HM-004	291	382	673	237	357	316	227	131	157	434
HM-008	291	382	673	237	357	316	227	131	157	434
HM-011	291	382	673	237	357	316	227	131	157	434
HM-020	369	400	769	304	427	420	274	178	173	491
HM-040	369	400	769	304	427	420	274	178	173	491
HM-060	384	407	791	324	467	481	294	198	174	494
HM-100	453	490	942	416	608	494	305	209	143	669
HM-150	453	490	942	416	608	494	305	209	143	669
HM-200	508	490	997	416	608	611	305	209	143	669
HM-300	508	490	997	416	608	611	305	209	143	669

Ordering Code

Example:

HM - ¹020 ²05 ³4 ⁴29 ⁵4 ⁶N ⁷0 ⁸0 ⁹N ¹⁰0 ¹¹0 ¹²0 ¹³0

1

Model	
004	HM-004
008	HM-008
011	HM-011
020	HM-020
040	HM-040
060	HM-060
100	HM-100
150	HM-150
200	HM-200
300	HM-300

2

Color	
05	● Grey (Munsell N6.5)
21	● Matte Grey (Munsell M2.5)
SP	● Other colors
NC	○ Nano Coating

3

Enclosure	
0	General purpose
1	IECEX/ATEX Flameproof: Ex db IIB
2	IECEX/ATEX Flameproof: Ex db IIB +H2
3	KCs Flameproof: Ex db IIB
4	KCs Flameproof: Ex db IIB +H2
5	EAC Flameproof: Ex db IIB
6	EAC Flameproof: Ex db IIB +H2

4

RPM	
18	18 (50 Hz)
21	21 (60 Hz)
24	24 (50 Hz)
29	29 (60 Hz)
36	36 (50 Hz)
43	43 (60 Hz)
48	48 (50 Hz)
57	57 (60 Hz)
72	72 (50 Hz)
86	86 (60 Hz)
96	96 (50 Hz)
B5	115 (60 Hz)

5

Input Voltage	
1	1-Phase 110V
2	1-Phase 220V
3	3-Phase 220V
4	3-Phase 380V
5	3-Phase 440V
6	3-Phase 460V
7	3-Phase 480V

6

Cable entry	
P	4 x PF1", 1 x PF1½"
N	4 x NPT1", 1 x NPT1½"

7

Control	
0	On-off
1	Proportional Control Unit (input/output: 0 – 10 V dc or 4 – 20 mA dc)
2	CPT: Current Position Transmitter (output: 4-20 mA dc)

8

Communication	
0	N/A
1	Profibus (single) communication protocol
2	Profibus (dual) communication protocol
3	Modbus (single) communication protocol
4	Modbus (dual) communication protocol

9

Additional Monitoring Switches	
0	N/A
1	+4 AMS
2	+8 AMS
3	+12 AMS

10

IP Rating	
0	IP67
1	IP68 (10 m 72 hr)

11

Temperature	
0	Standard: -20 to +70 °C
	Flameproof: -20 to +60 °C
L	Low temperature: -60 to +60 °C (EAC)

12

Handle	
0	Standard
G	GBH: Gearbox Handwheel

13

Other Options	
0	N/A
F	FPA: Fire Proofing Actuator
I	ICM: Independent Control Moduel
A	ASC: Actuator body and control unit separated

Electric Linear Actuator HL Series

Features

- Variety of options are available
- Lightweight, robust, and has high corrosion protection
- Precise modulating control (300:1 at maximum stroke) as an option
- Flameproof (Ex db IIB T4) and dust ignition proof (Ex tb IIIC T135°C) enclosures as an option
- Maximum output force up to 25,000 N
- Communication (PROFIBUS, MODBUS) options

Description

Providing safe and reliable operation, the HL Series electric linear actuator is designed for linear valve applications, such as globe valve.

Wide range of application

With reliable and stable operation, the HL Series is used in many industries:

- Oil & gas
- Power plant
- Chemical & petrochemical
- Water
- Marine & shipbuilding
- General industries

High corrosion protection

The housings of all HL Series actuator are made from high grade aluminum alloys which are robust and light weight. To provide high corrosion resistance, the housings are anodized on the inside & outside and polyester powder coating is further applied on the outside. For usage in severe corrosive environments, nano-coating could be applied to the HL Series to enhance corrosion protection.

Wide range of output force

The maximum output force of the HL Series ranges from 5,000 to 25,000 N.

Board spectrum of options

The HL Series has a board spectrum of options to be used in many different environments and satisfy user's needs.

Certificates and approvals

- IECEx (Ex db IIB T4 Gb, Ex tb IIIC T135°C Db)
- ATEX (II 2G Ex db IIB T4 Gb, II 2D Ex tb IIIC T135°C Db)
- KCs (Ex d IIB T4 IP67)
- EAC (1 Ex db IIB T4 Gb X)
- CCC (Ex db IIB T4 Gb, Ex tb IIIC T135°C Db)

IECEX CE₀₃₄₄ Ex EAC CCC





Design Features

Position control unit

Limit switches & potentiometer

Body & Cover

High grade aluminum alloy anodized and polyester powder coated

Motor

1-Phase, 3-Phase, and 24 V dc

Force switch

SPDT 250 V ac 16 A

PCU (modulation card, option)

Proportional control unit output: 4-20 mA or 0-10 V

Upper base

Declutch lever & Manual handwheel

Proportional control unit output: 4-20 mA or 0-10 V

Driving rod

Guide rod

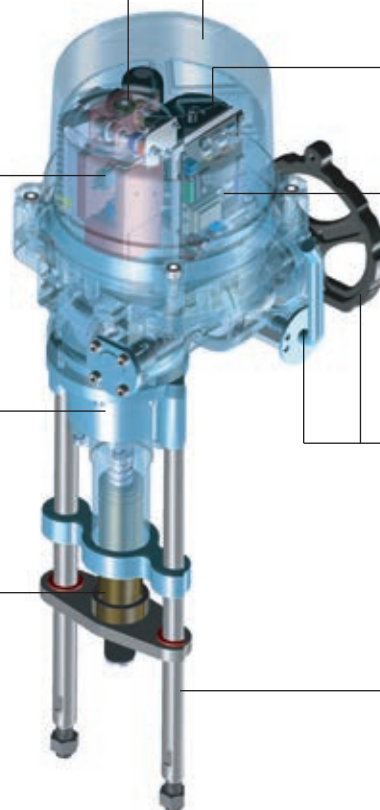

Performance Data & Specification

Performance

Model	Max. output force	Stem speed (mm/sec)	Max. stroke	Rated current (A)						No. of handle turn	Weight
				dc	ac, 1-phase, 50/60 Hz		ac, 3-phase, 50/60 Hz				
				24 V	110 V	220 V	380 V	440 V	460 V		
HL-05KN	5	0.44 / 0.53	60	2.1	1.0 / 1.0	0.6 / 0.5	0.3 / 0.3	0.6 / 0.4	N/A	227	11
HL-07KN	7	0.44 / 0.53	60	2.7	1.2 / 1.1	0.6 / 0.6	0.3 / 0.4	0.6 / 0.5	N/A	227	11
HL-10KN	10	0.69 / 0.82	70	3.9	1.9 / 1.8	0.9 / 0.9	0.6 / 0.4	0.6 / 0.4	0.6 / 0.3	184	21
HL-12KN	12	0.69 / 0.82	70	4.6	2.1 / 2.0	1.0 / 1.0	0.7 / 0.5	0.6 / 0.4	0.6 / 0.4	184	21
HL-15KN	15	0.69 / 0.82	80	5.6	2.2 / 2.1	1.1 / 1.1	0.7 / 0.5	0.7 / 0.4	0.6 / 0.4	210	21
HL-18KN	18	0.69 / 0.83	100	5.8	1.8 / 2.0	0.9 / 1.1	0.6 / 0.5	0.4 / 0.3	0.4 / 0.3	260	33
HL-20KN	20	0.69 / 0.83	100	6.4	2.1 / 2.4	1.0 / 1.2	0.7 / 0.6	0.7 / 0.5	0.7 / 0.5	260	33
HL-25KN	25	0.69 / 0.83	100	7.8	3.2 / 4.0	1.9 / 2.1	0.9 / 0.8	0.8 / 0.6	0.8 / 0.6	260	33

Standard Specification

Enclosure	Weatherproof enclosure IP66/IP67 High grade aluminium alloy, hard anodized & polyester powder coated		
Max. output force	5,000 to 25,000 N (see the performance table above)		
Power supply	24 V dc 1-Phase: 110/220 V ac, 50/60 Hz 3-Phase: 220/ 380/440/460 V ac, 50/60 Hz		
Voltage tolerance	±10%		
Duty cycle (on-off)	S2 30 min (room temperature, average load of 50% of maximum force)		
Motor	Induction motor (reversible motor)	Cable entries	2 x PF3/4" or 2 x NPT3/4" or 2 x M25
Ambient temperature	-20 to +70 °C	Limit switches	Open/close, 2-SPDT, 250 V ac 16 A rating
Ambient humidity	90% Max. RH (non-condensing)	Force switches	Open/close, 2-SPDT, 250 V ac 16 A rating
Self locking	By double worm gear	Lubrication	Grease moly (EP type)
Manual operation	Declutchable manual override	Terminal block	Spring loaded lever push type
Space heater	HL-05KN, 07KN: 5 W, HL-10KN to 25KN: 10 W, anti-condensation		
Stall protection	Built-in thermal protection, motor stops at 150±5 °C and re-starts at 97±5 °C		
Coating (color)	● Grey (RAL 7046), ● Red (RAL 3001), ● Blue (RAL 5005), ● Yellow (RAL 1033)		

Optional Specification

Enclosure	EXD Flameproof enclosure: Ex db IIB T4 (ambient temperature: -20 to +60 °C, cable entries: 4 x NPT1", 1 x NPT1½") ExtD Dust ignition proof enclosure: Ex tb IIIC T135°C (ambient temperature: -20 to +60 °C, cable entries: 4 x NPT1", 1 x NPT1½") WTA Watertight enclosure: IP68 (10 m 72 hr)
Power	ADCM 24 V ac/dc
Additional switch	ALS Additional Limit Switches, (+2-SPDT, 250 V ac 16 A rating)
Ambient temperature	LT Low Temperature: -60 to +60 °C (EAC), lubrication: tribolube-18
Control	PCU Proportional Control Unit (modulating), input/output: 0-10 V dc or 4-20 mA dc (duty cycle) S4 40-70%, 800-1,200 starts/hour (room temperature, average load of 50% of maximum force) CPT Current Position Transmitter/output, output: 4-20 mA dc PIU Potentiometer unit (0-1 kΩ) PROFI Registered PROFIBUS DP interface modules MODBUS Modbus modules
Local control	LCU-B Local Control Unit-B: LED local control unit (integral switch) RBP Rechargeable Battery Pack for emergency fail safe operation LCU-B(EX) Explosion proof LED local control unit (integral switch, Ex db IIB T4, Ex tb IIIC T135°C Db) LCU-2B(EX) Explosion proof LED local control unit (integral switch, separate terminal box, Ex db IIB T4, Ex tb IIIC T135°C Db)
Coating (color)	● Other colors, ○ Nano coating (for corrosive environment)

Dimensional Drawing

Standard

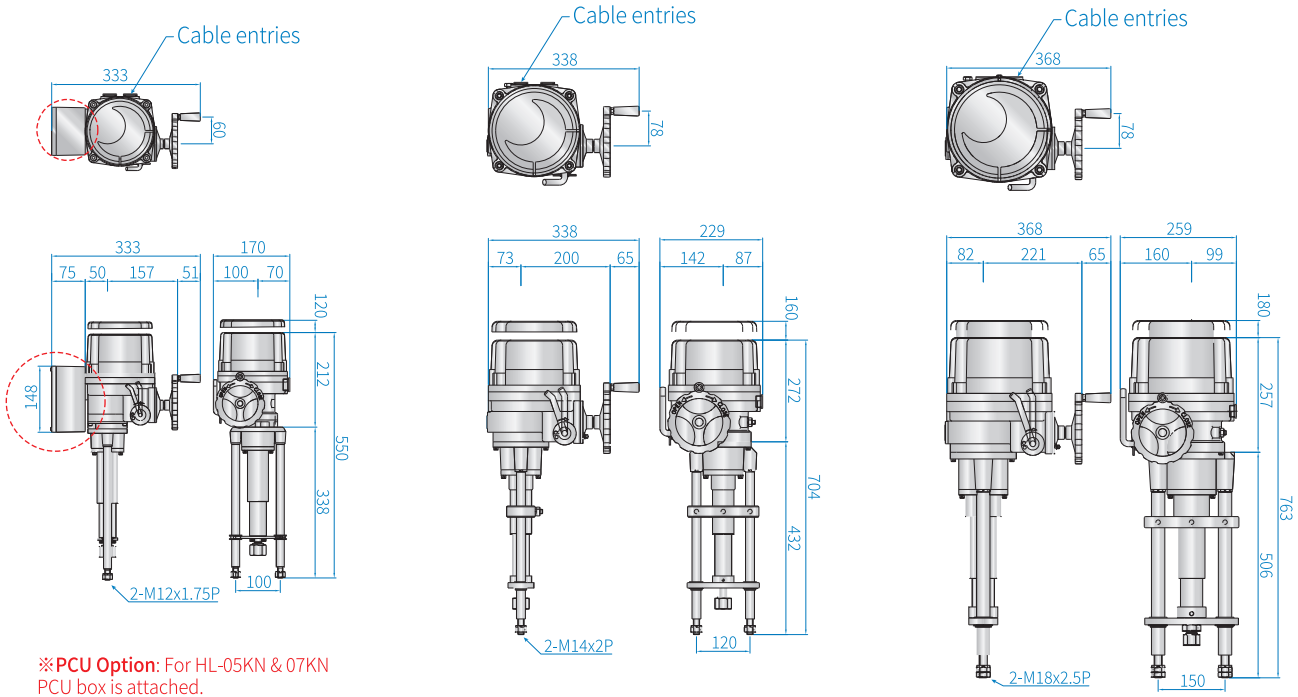

※PCU Option: For HL-05KN & 07KN
PCU box is attached.

HL-05KN, 07KN

HL-10KN, 12KN, 15KN

HL-18KN, 20KN, 25KN

Local Control Unit-B: LCU-B

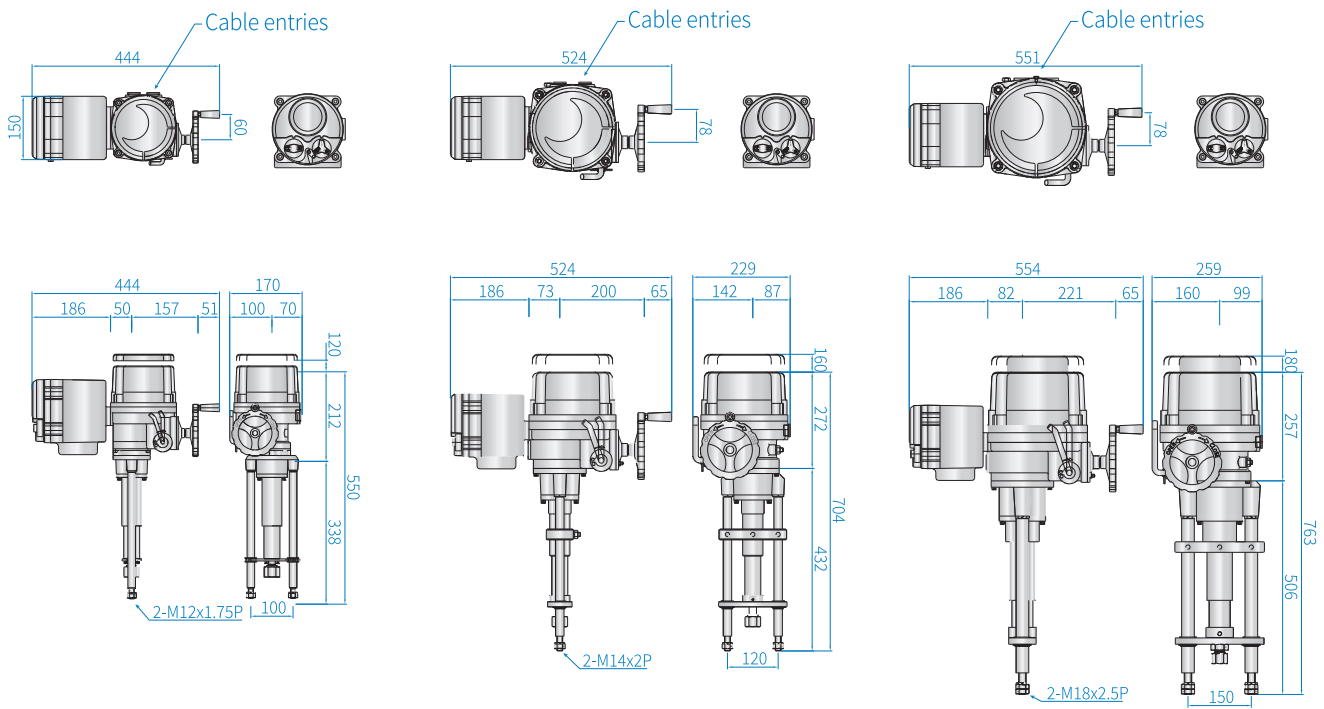

HL-05KN, 07KN

HL-10KN, 12KN, 15KN

HL-18KN, 20KN, 25KN

Rechargeable Battery Pack: RBP

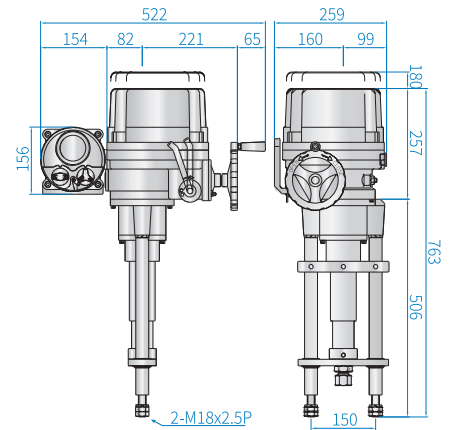
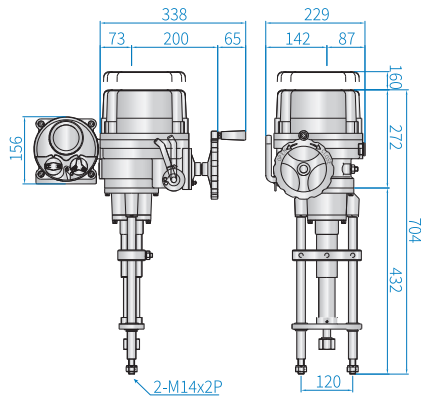
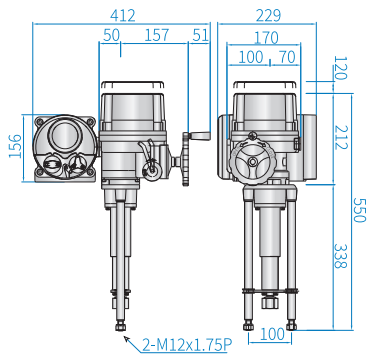
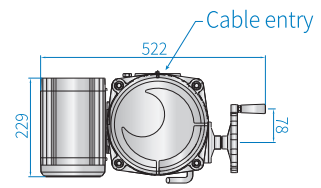
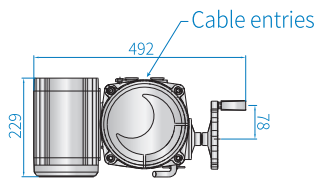
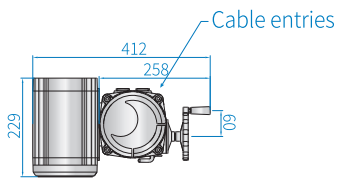

HL-05KN, 07KN

HL-10KN, 12KN, 15KN

HL-18KN, 20KN, 25KN

Explosion Proof Local Control Unit-B(EX): LCU-B(EX)

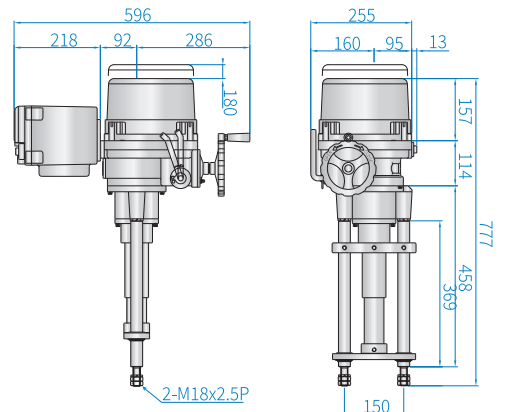
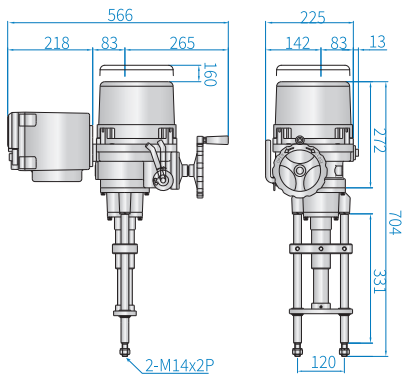
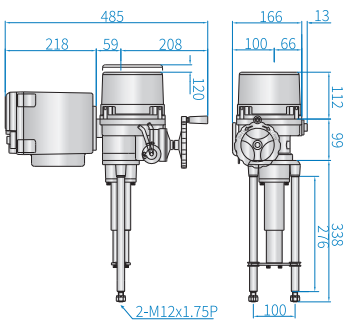
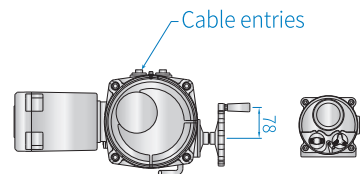
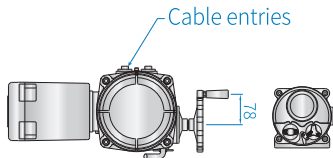
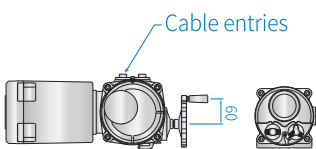

HL-05KN, 07KN

HL-10KN, 12KN, 15KN

HL-18KN, 20KN, 25KN

Dimensional Drawing

Explosion Proof Local Control Unit-2B(EX): LCU-2B(EX)

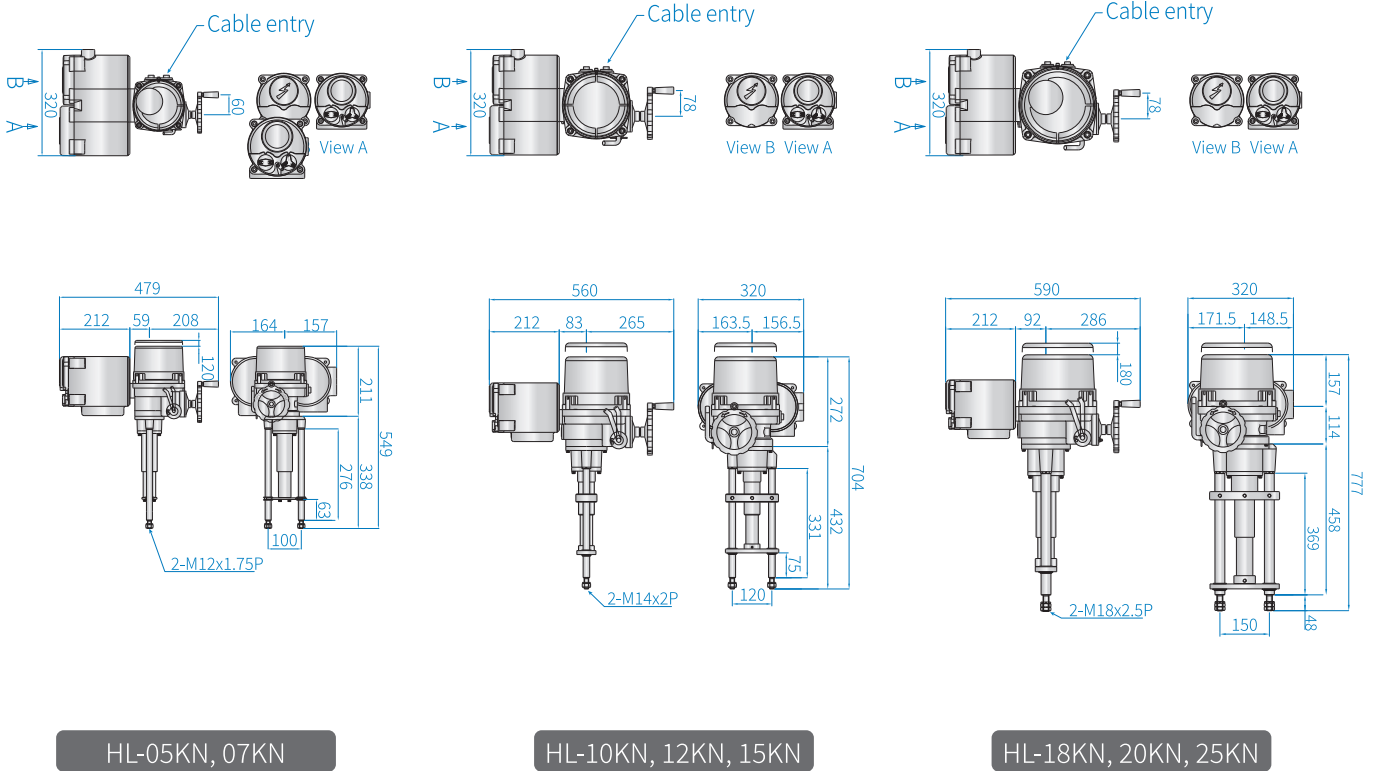

MODBUS / PROFIBUS

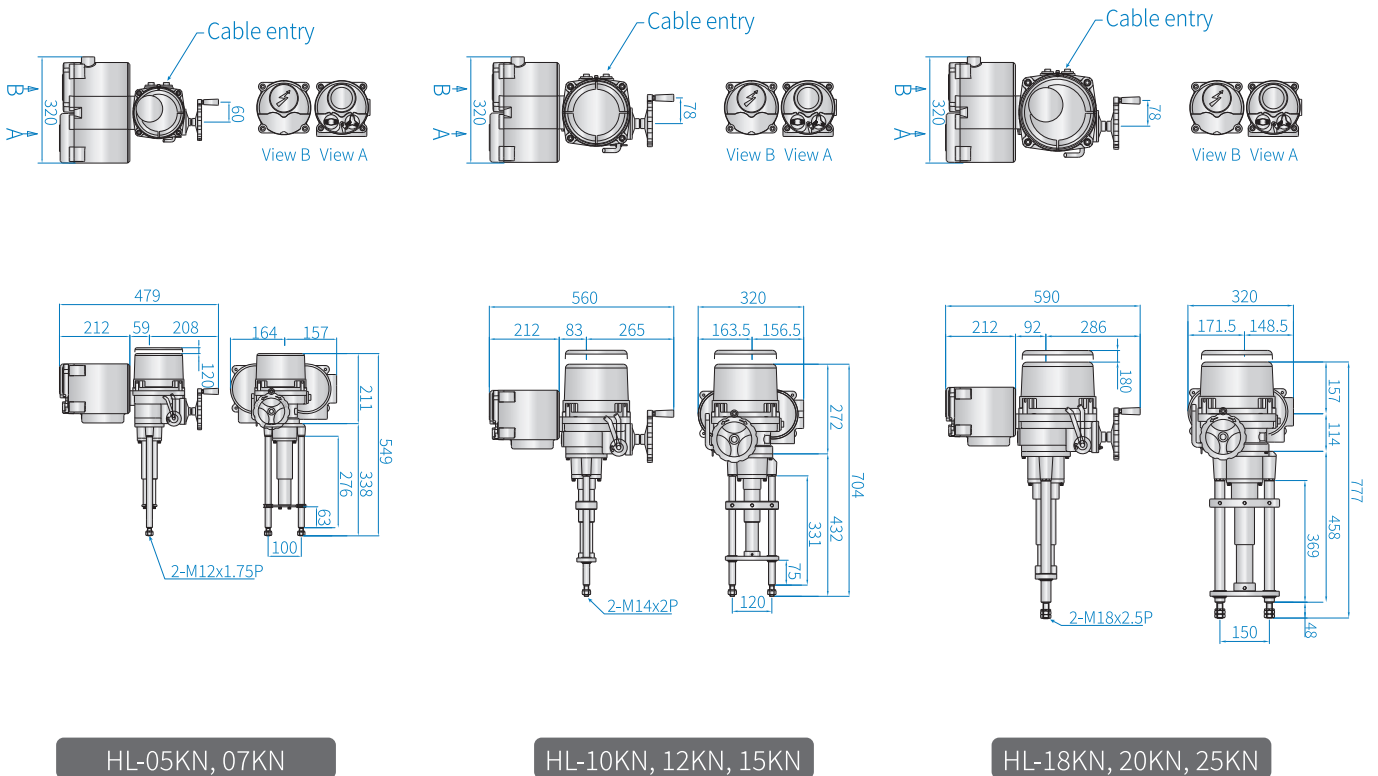

Ordering Code

Example:

HL - ¹05 ²21 ³A ⁴31 ⁵M ⁶0 ⁷0 ⁸00 ⁹0 ¹⁰0 ¹¹0 ¹²0

1

Model	
05	HL-05KN
07	HL-07KN
10	HL-10KN
12	HL-12KN
15	HL-15KN
18	HL-18KN
20	HL-20KN
25	HL-25KN

2

Color	
21	Grey (RAL 7046)
06	Red (RAL 3001)
16	Blue (RAL 5005)
11	Yellow (RAL 1033)
SP	Other colors
NC	Nano Coating

3

Enclosure	
0	General purpose
A	Flameproof: Ex db IIB
T	Dust ignition proof: Ex tb IIIC

4

Power	
10	1-Phase 110V
11	1-Phase 220V
30	3-Phase 220V
31	3-Phase 380V
32	3-Phase 440V
33	3-Phase 480V
D1	24V DC
D2	24V AC/DC

5

Cable entry	
P	3 x PF3/4"
N	2 x NPT3/4"
M	2 x M25

6

Control	
0	On-off
P	PIU: Potentiometer unit (0-1 kΩ)
C	CPT: Current Position Transmitter (output: 4-20 mA dc)
M	PCU: Proportional Control Unit (input/output: 0 – 10 V dc or 4 – 20 mA dc)

7

Communication	
0	N/A
1	Profibus (single) communication protocol
2	Profibus (dual) communication protocol
3	Modbus (single) communication protocol
4	Modbus (dual) communication protocol

8

Local Control Unit	
00	N/A
A1	Local Control Unit-B: LCU-B
D0	Rechargeable Battery Pack: RBP
E0	Explosion proof Local Control Unit-B: LCU-B(EX)
E1	Explosion proof Local Control Unit-2B: LCU-2B(EX)

9

Additional S/W	
0	N/A
1	ALS: +2-SPDT (limit s/w)

10

IP Rating	
0	IP66
1	IP67
2	IP68 (10 m 72 hr)

11

Temperature	
0	Standard: -20 to +70 °C
	Flameproof: -20 to +60 °C
L	Low temperature: -60 to +60 °C (EAC)

12

Other Options	
0	N/A
F	FPA: Fire Proofing Actuator

Electric Part-turn Actuator HQ Series

Description

Providing safe and reliable operation, the HQ Series electric part-turn actuators are designed for quarter-turn valves, such as ball valve, butterfly valve, plug valve, damper, and etc.

Wide range of application

With reliable and stable operation, the HQ Series is used in many industries:

- Oil & gas
- Power plant
- Chemical & petrochemical
- Water
- Marine
- General industries

Wide range of torque

The maximum torque of the HQ Series ranges from 40 to 9,000 Nm.

High corrosion protection

The covers and bodies of HQ Series actuator are made from high grade aluminum alloys which are robust and light weight. To provide high corrosion resistance, they are either chromate treated twice (HQ-004 to HQ-006) or hard-anodized (HQ-008 to HQ-900) on the inside & outside and polyester powder coating is further applied on the outside. For usage in severe corrosive environments, nano-coating could be further applied to the HQ Series to enhance corrosion protection.

Board spectrum of options

The HQ Series has a board spectrum of options which can be combined to customize the actuator to satisfy the user's needs.

- **Enclosure:**
 - weather proof: IP67, NEMA4, 4X & 6
 - watertight: IP68
 - flameproof: Ex db IIB T4
 - dust ignition proof: Ex tb IIIC T135°C
- **Local Control Unit (LCU) options**
 - LCU-Z: LED lamp indicator
 - LCU-B: LED lamp indicator & integral switch
 - LCU-C: LCD display & integral switch
 - LCU-2B EX: explosionproof
 - RBP: battery backup actuator
- **Control options**
 - PCU: Proportional Control Unit (modulation)
 - CPT: Current Position Transmitter
 - PIU: Potentiometer unit
- **Communications**
 - PROFIBUS, MODBUS, CANBUS
- **Wide range of voltages**
 - 110/220 V ac 1-phase
 - 220, 380, 440, 460, 480 V ac 3-phase
 - 24V dc (upto 3,000 Nm)
- **Color**
 - Red (RAL 3001), blue (RAL 5005), yellow (RAL 1033), grey (RAL 7046), light grey (RAL 7035), and etc.

※ See specification pages for more detail



Models



Electric Quarter-turn Actuator HQ-004

Features

- Aluminum die-cast, compact size, and light weight
- Multi-voltage: 85 to 265 V ac, 1-phase / 24 V dc
- Weatherproof enclosure IP67
- Push button and manual lever included.
- 4 limit switches and captive cover bolts
- Mechanical position indicator
- LED indicators for open & close

Certificates and approvals

- RINA type approval



Design Features

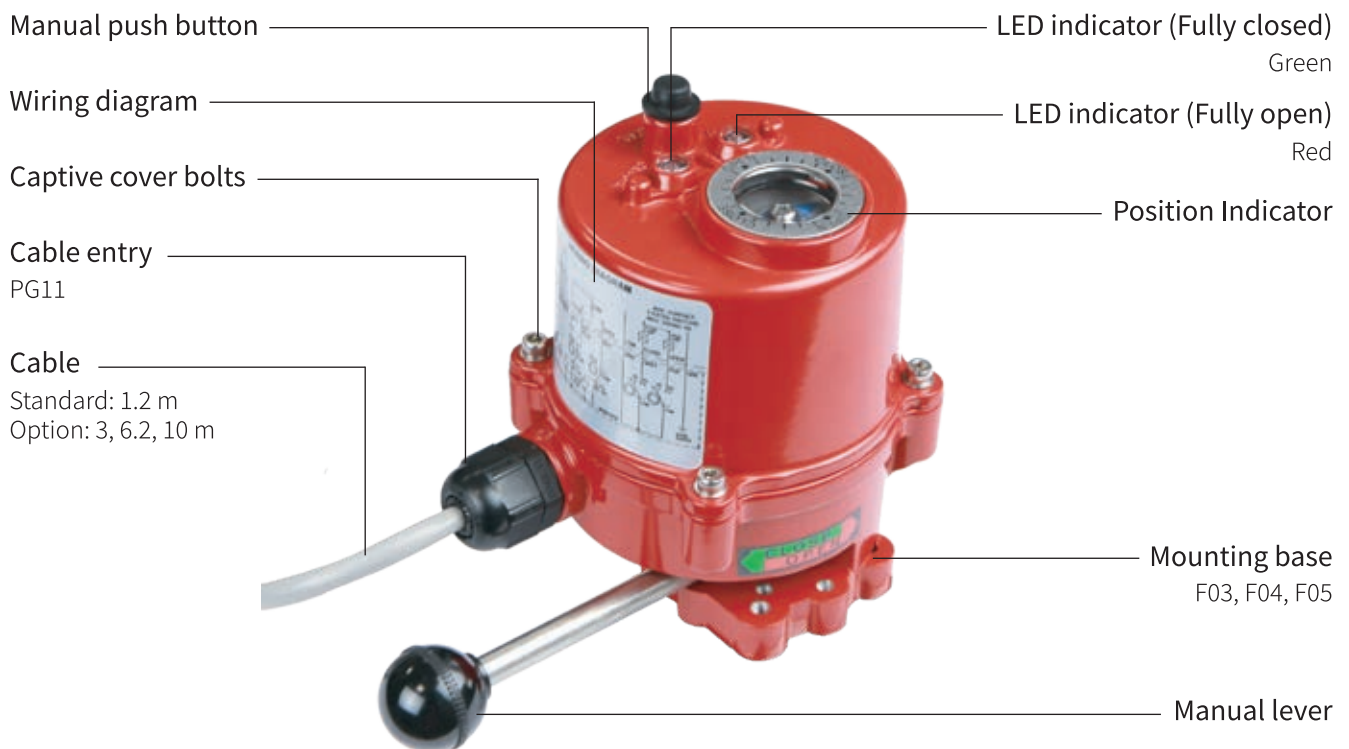

Specification

Standard Specification

Enclosure	Weatherproof enclosure IP67 High grade aluminium alloy, chromate treated twice & polyester powder coated		
Max. torque output	40 Nm (recommended operating torque: 30 Nm)		
Power supply	1-Phase: 85-265 V ac, 50/60 Hz, ±10% & 24 V dc	Rated current	1-phase: 0.1 A 24 V dc: 0.5 A
Duty cycle (on-off)	S2 30 min (room temp., average load of 50% of maximum torque)	Travel angle	0 - 90°
Operating time	12 s	Limit switches	4 x SPDT (5 A 250 V ac)
Cable entry	PG11	Ambient temperature	-20 to +70 °C
Cable length	1.2 m	Lubrication	Grease moly (EP type)
No. of handle turns	8	Weight	1.2 kg
Flange size (ISO 5211)	F03, F04, F05/ star 11 mm or 14 mm		
Coating (color)	● Red (RAL 3001), ● Blue (RAL 5005), ● Yellow (RAL 1033), ● Grey (RAL 7046), ● Light grey (RAL 7035), ● Green (RAL 6034)		

Optional Specification

Operating time	HSA : high speed actuator with 7 s operating time (Max. torque output: 20 Nm)		
Power supply	12 V dc	Rated current	12 V dc: 1.0 A
Cable entry	M20	Cable length	3 m, 6.2 m, 10 m
Coating (color)	● Other colors , ○ Nano coating (for corrosive environment)		

Dimensional Drawing

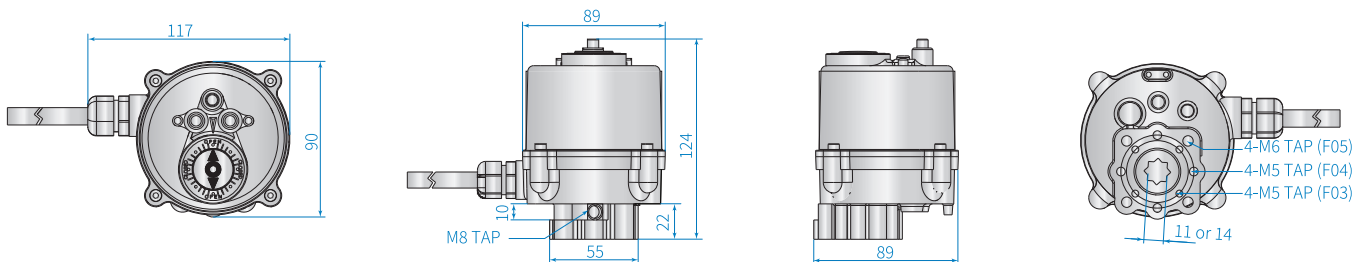

Wiring Diagram

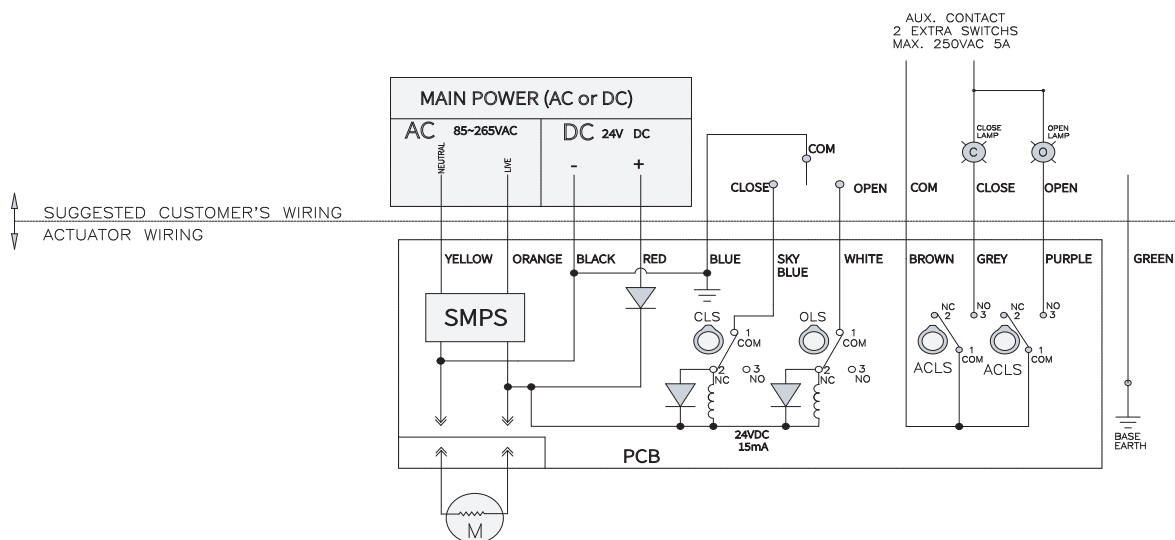

Electric Part-turn Actuator HQ-006

Features

- Aluminum die-cast, compact size, and light weight
- Reversible motor with high torque and low current
- Weatherproof IP67 or watertight IP68 option
- Manual lever
- Proportional Control Unit (PCU, modulating) option
- Local Control Unit (LCU) option
- MODBUS communication option



Certificates and approvals

- ABS type approval
- RMRS type approval
- Turk Loydu type approval
- RINA type approval
- USCG test approval
- IECEx (Ex db IIB T4 Gb)
- ATEX (II 2G Ex db IIB T4 Gb)
- KCs (Ex d IIB T4 Gb)
- CCC (Ex d IIB T4 Gb)
- SIL 2 (SC 3)

IECEX

CE 0344



Design Features



Specification

Standard Specification

Enclosure	Weatherproof enclosure IP67 High grade aluminium alloy, chromate treated twice & polyester powder coated		
Max. torque output	60 Nm		
Power supply	1-Phase: 110/220 V ac, 50/60 Hz, $\pm 10\%$	Rated current	1-phase 110 V ac: 0.4 A 1-phase 220 V ac: 0.2 A
Duty cycle (on-off)	S2 30 min (room temp., average load of 50% of maximum torque)	Travel angle	0 - 90 °, 120 °, 135 °, 180 °, 270 °, 340 °, etc.
Operating time	14 s (50 Hz), 12 s (60 Hz)	Limit switches	4 x SPDT (5 A 250 V ac)
Cable entry	2 x PG13.5, 2 x PF1/2", 2 x NPT1/2", 2 x M20	Ambient temperature	-20 to +70 °C
Weight	3 kg	Lubrication	Grease moly (EP type)
No. of handle turns	8	Space heater	2 W (110/220 V ac), anti-condensation
Flange size (ISO 5211)	F03, F05, F07 / star 14 mm (please see dimensional drawing below)		
Coating (color)	● Red (RAL 3001), ● Blue (RAL 5005), ● Yellow (RAL 1033), ● Grey (RAL 7046), ● Light grey (RAL 7035), ● Green (RAL 6034)		

Optional Specification

Enclosure rating	WTA Watertight enclosure actuator (IP68 10 m 72 hr)		
Power supply	DC 24 V dc ADCM 24 V ac/dc	Rated current	24 V dc: 1.7 A 24 V ac/dc: 1.7 A
Control	Control box is attached : Weatherproof enclosure IP67, Weight: 4.2 kg, Cable entry: 2 x PG13.5 PCU Proportional Control Unit (modulating), input/output: 0-10 V dc or 4-20 mA dc (duty cycle) S4 40%, 800-1,200 starts/hour (room temperature, average load of 50% of maximum force) CPT Current Position Transmitteroutput, output: 4-20 mA dc PIU Potentiometer unit (0-1 k Ω) MODBUS Modbus modules		
Local control	LCU-D Local control unit (remote/local & open/stop/close) LCU-Z Local control unit (remote/local & open/stop/close) with LED lamp indicators		
Coating (color)	● Other colors , ○ Nano coating (for corrosive environment)		

Explosion Proof Specification

Enclosure	Weatherproof enclosure IP67 High grade aluminium alloy, chromate treated twice & polyester powder coated		
Max. torque output	60 Nm		
Power supply	1-Phase: 110/220 V ac, 50/60 Hz, $\pm 10\%$	Rated current	1-phase 110 V ac: 0.4 A 1-phase 220 V ac: 0.2 A
Duty cycle (on-off)	S2 30 min (room temp., average load of 50% of maximum torque)	Travel angle	0 - 90 °, 120 °, 135 °, 180 °, 270 °, 340 °, etc.
Operating time	14 s (50 Hz), 12 s (60 Hz)	Limit switches	4 x SPDT (5 A 250 V ac)
Cable entry	2 x NPT1/2", 2 x M20	Ambient temperature	-20 to +60 °C
Weight	4.2 kg	Lubrication	Grease moly (EP type)
No. of handle turns	8	Space heater	2 W (110/220 V ac), anti-condensation
Flange size (ISO 5211)	F04, F05, F07 / star 14 mm (please see dimensional drawing below)		
Coating (color)	● Red (RAL 3001), ● Blue (RAL 5005), ● Yellow (RAL 1033), ● Grey (RAL 7046), ● Light grey (RAL 7035), ● Green (RAL 6034)		

Explosion Proof Optional Specification

Enclosure rating	WTA Watertight enclosure actuator (IP68 10 m 72 hr)		
Power supply	DC 24 V dc ADCM 24 V ac/dc	Rated current	24 V dc: 1.7 A 24 V ac/dc: 1.7 A
Coating (color)	● Other colors , ○ Nano coating (for corrosive environment)		

Dimensional Drawing

Standard

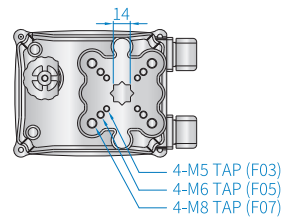
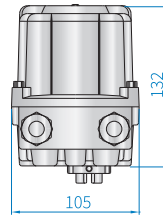
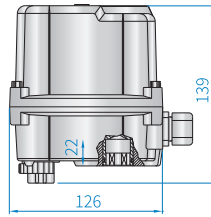
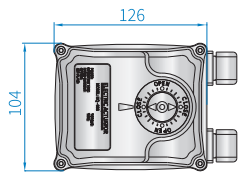

Control Box (PCU, CPT, PIU)

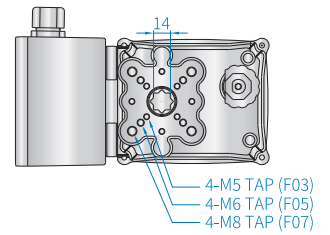
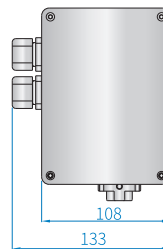
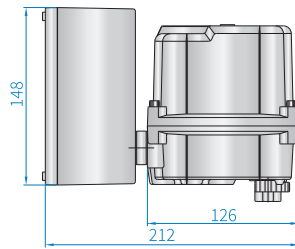
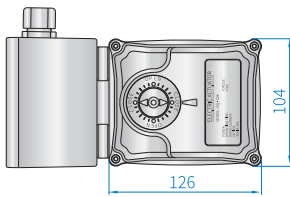

Local Control Unit-D: LCU-D

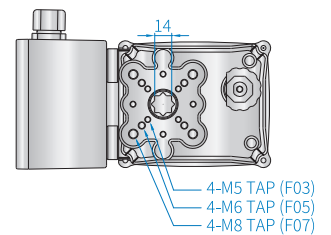
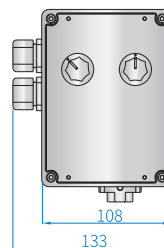
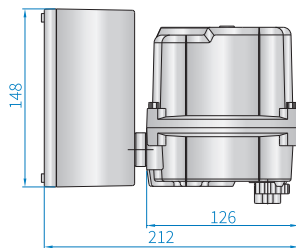
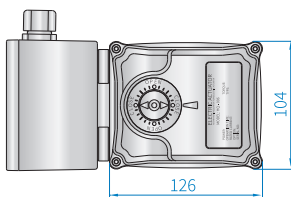

Local Control Unit-Z: LCU-Z

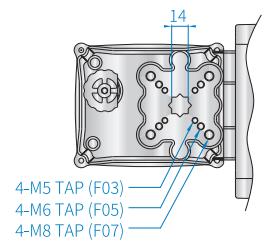
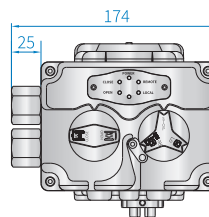
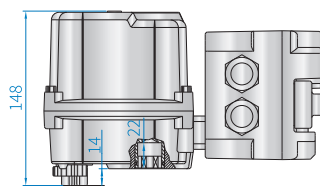
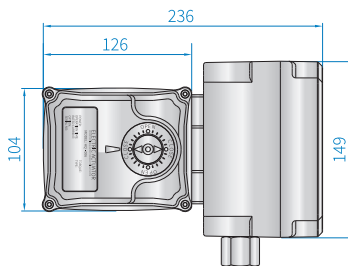

Explosion Proof HQ-006

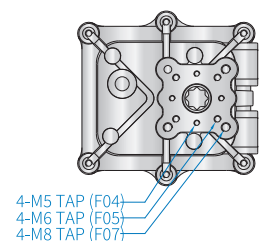
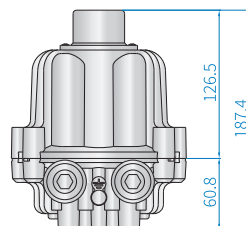
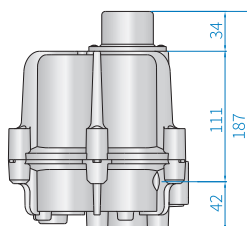
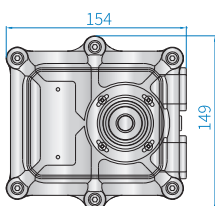

Electric Part-turn Actuator HQ-008 to HQ-900



Features

- Listed as a World Class Korea product since 2013
- Variety of options are available
- Lightweight, robust, and has high corrosion protection
- Precise modulating control (250:1) as an option
- Maximum output torque up to 3,000 Nm with 24 V dc
- IP68 (upto 10 m, 72 hours) as an option
- Flameproof (Ex db IIB T4) and dust ignition proof (Ex tb IIIC T135°C) enclosures as an option
- Communication (PROFIBUS, MODBUS, CANOpen) options



Certificates and approvals

- IECEx (Ex db IIB T4 Gb, Ex tb IIIC T135°C Db)
- ATEX (II 2G Ex db IIB T4 Gb, II 2D Ex tb IIIC T135°C Db)
- KCs (Ex d IIB T4, Ex tD A21 IP6X, T135°C)
- EAC (1 Ex db IIB T4 Gb X, Ex tb IIIC T135°C Db)
- CSA (Class I, Division 1, Groups C,D T4; Ex d IIB T4 Gb)
- CCC (Ex db IIB T4 Gb, Ex tb IIIC T135°C Db)
- SIL 2 (SC 3)
- RMRS type approval
- ABS type approval
- Turk Loydu type approval
- RINA type approval
- USCG test approval



Design Features

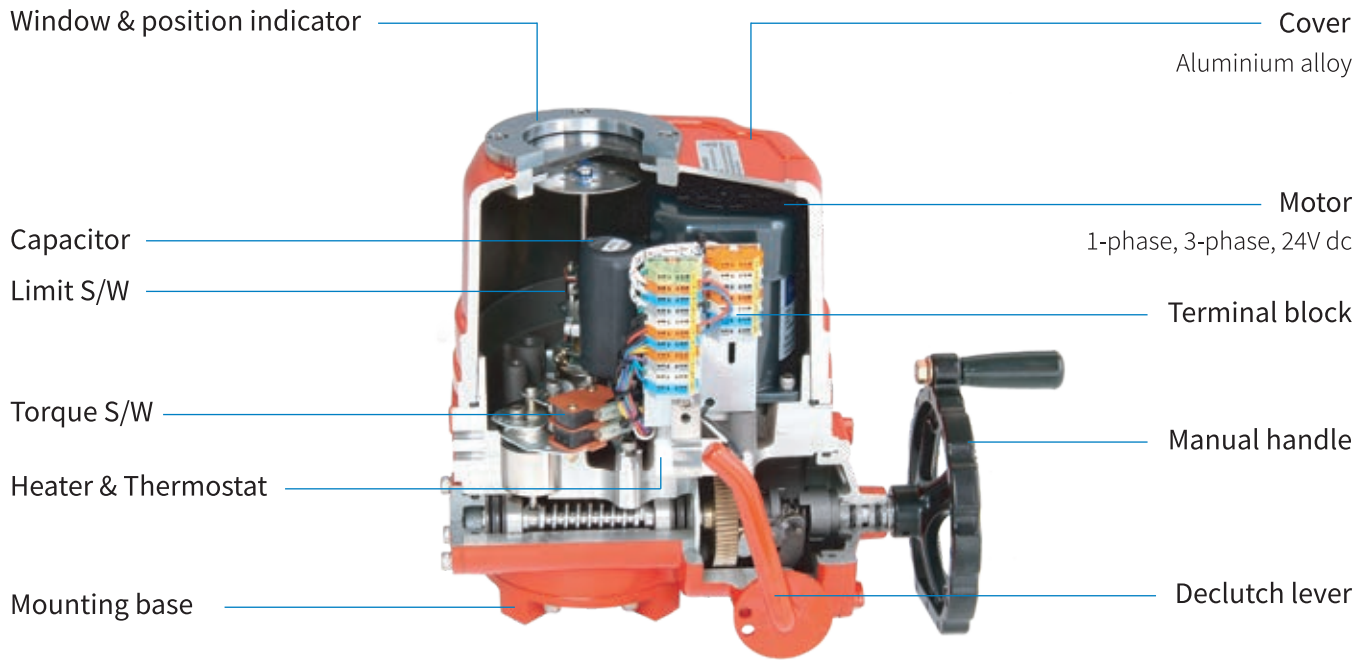

Performance

Model	Max. output torque Nm	Operating time (sec) 50/60 Hz 90°	Rated current (A), (50/60 Hz)								Mounting bore size Ø mm	No. of handle turns n	Weight kg
			dc 24 V	ac, 1-phase, 50/60 Hz				ac, 3-phase, 50/60 Hz					
				100 V	110 V	200 V	220 V	380 V	440 V	460 V			
HQ-008	80	16/13	3.7	1.3/1.3	1.2/1.1	0.7/0.6	0.6/0.6	0.2/0.3	0.6/0.4	N/A	20	10	7
HQ-010	100	20/17	4.0	1.3/1.3	1.2/1.1	0.7/0.7	0.7/0.6	0.2/0.3	0.6/0.4	N/A	20	10	7
HQ-015	150	25/21	5.3	2.4/2.2	2.1/2.1	1.1/1.1	1.0/1.0	0.6/0.4	0.6/0.4	0.6/0.4	22	11	17
HQ-020	200	25/21	6.5	2.5/2.3	2.2/2.1	1.2/1.2	1.1/1.1	0.7/0.5	0.6/0.4	0.6/0.4	22	11	17
HQ-030	300	31/26	8.6	2.3/2.7	2.1/2.4	1.1/1.4	1.0/1.3	0.6/0.5	0.4/0.3	0.4/0.3	35	13.5	22
HQ-050	500	31/26	N/A	3.6/4.6	3.3/4.2	1.9/2.1	1.7/1.9	0.9/0.8	0.8/0.5	0.7/0.5	35	13.5	23
HQ-060	600	31/26	7.0	3.8/4.9	3.4/4.4	2.1/2.3	1.9/2.0	1.0/0.9	1.4/0.9	1.3/0.9	35	13.5	23
HQ-080	800	37/31	8.6	6.0/6.3	5.4/5.7	2.9/3.1	2.6/2.8	1.3/1.0	1.7/0.9	1.6/0.9	45	16.5	29
HQ-120	1,200	37/31	8.6	7.2/7.6	6.5/6.9	3.1/3.3	2.8/3.0	1.5/1.1	1.8/1.0	1.7/0.9	45	16.5	29
HQ-200	2,000	112/93	8.6	6.0/6.3	5.4/5.7	3.4/3.3	3.1/3.0	1.4/1.0	1.7/1.0	1.6/0.9	65	49.5	75
HQ-270	2,700	56/47	N/A	7.2/7.4	6.3/6.7	3.5/3.4	3.2/3.1	1.5/1.1	1.8/1.0	1.7/0.9	65	49.5	75
HQ-300	3,000	112/93	8.6	7.2/7.6	6.5/6.9	3.1/3.3	2.8/3.0	1.5/1.1	1.8/1.0	1.7/0.9	65	49.5	75
HQ-350	3,500	39/33	N/A	N/A	N/A	N/A	11.2/8.7	4.2/3.0	3.8/2.6	N/A	75	42	75
HQ-400	4,000	58/49	N/A	N/A	N/A	N/A	11.2/8.7	4.2/3.0	3.8/2.6	N/A	75	42	75
HQ-600	6,000	78/66	N/A	N/A	N/A	N/A	9.0/6.3	3.6/3.3	2.1/1.8	N/A	110	84	215
HQ-800	8,000	116/98	N/A	N/A	N/A	N/A	9.0/6.3	3.6/3.3	2.1/1.8	N/A	110	84	215
HQ-900	9,000	117/99	N/A	N/A	N/A	N/A	9.0/6.3	3.6/3.3	2.1/1.8	N/A	110	84	215

Specification

Standard Specification

Material	High grade aluminium alloy, nodular cast iron, aluminium bronze, steel, polycarbonate	All
External coating	Hard anodizing treatment and polyester powder coating	All
Enclosure	Weatherproof enclosure IP67	All
	NEMA Type 4, 4X, 6, IP66, IP67	HQ-008 to HQ-300
Power	100, 110 V ac 1 ph, 50/60 Hz, $\pm 10\%$	HQ-008 to HQ-300
	200 to 240 V ac 1 ph, 50/60 Hz, $\pm 10\%$	All
	200 to 240 V ac 3 ph, 50/60 Hz, $\pm 10\%$	HQ-015 to HQ-900
	380, 400, 440, 460, 480 V ac 3 ph, 50/60 Hz, $\pm 10\%$	All
	12 V dc	HQ-008 to HQ-010
	24 V dc	HQ-008 to 300 (except 050, 270)
Duty cycle (on-off)	S2 30 min (room temperature, average load of 50% of maximum force)	All
Motor	Induction motor (reversible motor)	All
Ambient temperature	-20 to +70 °C	All
Ambient humidity	90% max. RH (non-condensing)	All
Cable entries	2 x PF3/4", 2 x NPT3/4", 2 x M25, 2 x M20	HQ-008 to HQ-300
	2 x PF3/4" + PF1"	HQ-350 to HQ-900
Limit switches	2-SPDT (open/close), 250 V ac 16 A rating	HQ-008 to HQ-010
	4-SPDT (open/close), 250 V ac 16 A rating	HQ-015 to HQ-900
Torque switches	2-SPDT (open/close), 250 V ac 16 A rating	HQ-015 to HQ-900
Travel angle	90 \pm 10° (0-110°) clockwise to close	All
Manual operation	Declutchable manual override	All
Self locking	Provided by double worm gear	All
Space heater	5 W (100, 110, 200 to 240 V ac 1 ph, 12/24 V dc), anti-condensation	HQ-008 to HQ-010
	10 W (100, 110, 200 to 240 V ac 1 ph, 12/24 V dc), anti-condensation	HQ-015 to HQ-900
Stall protection	Built-in thermal protection (thermostat), opens at 150 \pm 5°C and closes at 97 \pm 15°C	All
Anti vibration	XYZ 10g, 0.2-34 Hz, 30 min	All
Lubrication	Grease moly (EP type)	All
Coating (color)	● Red (RAL 3001), ● Blue (RAL 5005), ● Yellow (RAL 1033), ● Grey (RAL 7046), ● Light grey (RAL 7035), ● Green (RAL 6034)	

Optional Specification

Enclosure	WTA watertight enclosure IP68 (10 m 72 hours)	All
Power	ADCM multi ac-dc 24 V (integral)	HQ-008 to 300 (except 050, 270)
Ambient temperature	LT low temperature (-60 to +60 °C)	All
Additional switch	ALS additional limit switches, 2-SPDT (open/close), 250 V ac 16 A rating	All
	ATS additional torque switches, 2-SPDT (open/close), 250 V ac 16 A rating	HQ-015 to HQ-900
High speed	High speed actuator (2L , 3L)	HQ-008 to HQ-300
Travel angle	EXT extension 120°, 135°, 180°, 270°, etc.	All
	R reverse operation, 90 \pm 10° (0-110°) counter-clockwise to close	All
Control	PIU potentiometer unit (0-1 k Ω)	All
	*1 CPT current position transmitter (4-20 mA dc)	All
	*1 PCU Proportional Control Unit (modulating), input/output: 0-10 V dc or 4-20 mA dc (duty cycle) S4 40-70%, 800-1,200 starts/hour (room temperature, average load of 50% of maximum force)	All
	PROFI Registered PROFIBUS DP interface modules	All
	MODBUS Modbus modules	All
	CANopen CANopen modules	All
Local control	LCU-Z LED local control unit	All
	LCU-B LED local control unit (integral switch)	All
	LCU-C LCD local control unit (integral switch, auto phase discriminator, separate terminal box)	HQ-015 to HQ-900
	RBP Rechargeable Battery Pack for emergency fail safe operation	All
Coating (color)	● Other colors, ○ Nano coating (for corrosive environment)	All
Others	SPD Surge protection device (Max. 15 kW)	All
	FPA1 Fire proofing actuator (1050 \pm 5°C / 50 min), FPA2 Fire proofing actuator (250 \pm 5°C / 150 min)	All

Specification

Explosion Proof Specification

Material	High grade aluminium alloy, nodular cast iron, aluminium bronze, steel, polycarbonate	HQ-008 to HQ-300
External coating	Hard anodizing treatment and polyester powder coating	HQ-008 to HQ-300
Enclosure	Flameproof (Ex db IIB T4) - IECEx, ATEX, CSA, EAC, CCC, KCs	HQ-008 to HQ-300
	Dust ignition proof (Ex tb IIIC T135°C) - IECEx, ATEX, EAC, CCC, KCs	HQ-008 to HQ-300
	NEMA Type 4, 4X, 6, IP66, IP67	HQ-008 to HQ-300
Power	100, 110 V ac 1 ph, 50/60 Hz, ±10%	HQ-008 to HQ-300
	200 to 240 V ac 1 ph, 50/60 Hz, ±10%	HQ-008 to HQ-300
	200 to 240 V ac 3 ph, 50/60 Hz, ±10%	HQ-015 to HQ-300
	380, 400, 440, 460, 480 V ac 3 ph, 50/60 Hz, ±10%	HQ-008 to HQ-300
	12 V dc	HQ-008 to HQ-010
	24 V dc	HQ-008 to 300 (except 050, 270)
Duty cycle (on-off)	S2 30 min (room temperature, average load of 50% of maximum force)	HQ-008 to HQ-300
Motor	Induction motor (reversible motor)	HQ-008 to HQ-300
Ambient temperature	-20 to +60 °C	HQ-008 to HQ-300
Ambient humidity	90% max. RH (non-condensing)	HQ-008 to HQ-300
Cable entries	2 x NPT3/4", 2 x M25, 2 x M20	HQ-008 to HQ-300
Limit switches	2-SPDT (open/close), 250 V ac 16 A rating	HQ-008 to HQ-010
	4-SPDT (open/close), 250 V ac 16 A rating	HQ-015 to HQ-300
Torque switches	2-SPDT (open/close), 250 V ac 16 A rating	HQ-015 to HQ-300
Travel angle	90±10° (0-110°) clockwise to close	HQ-008 to HQ-300
Manual operation	Declutchable manual override	HQ-008 to HQ-300
Self locking	Provided by double worm gear	HQ-008 to HQ-300
Space heater	5 W (100, 110, 200 to 240 V ac 1 ph, 12/24 V dc), anti-condensation	HQ-008 to HQ-010
	10 W (100, 110, 200 to 240 V ac 1 ph, 12/24 V dc), anti-condensation	HQ-015 to HQ-300
Stall protection	Built-in thermal protection (thermostat), opens at 150±5°C and closes at 97±15°C	HQ-008 to HQ-300
Anti vibration	XYZ 10g, 0.2-34 Hz, 30 min	HQ-008 to HQ-300
Lubrication	Grease moly (EP type)	HQ-008 to HQ-300
Coating (color)	● Red (RAL 3001), ● Blue (RAL 5005), ● Yellow (RAL 1033), ● Grey (RAL 7046), ● Light grey (RAL 7035), ● Green (RAL 6034)	

Explosion Proof Optional Specification

Enclosure	WTA watertight enclosure IP68 (10 m 72 hours)	HQ-008 to HQ-300
Power	ADCM multi ac-dc 24 V (integral)	HQ-008 to 300 (except 050, 270)
Ambient temperature	LT low temperature (-60 to +60 °C)	HQ-008 to HQ-300
Additional switch	ALS additional limit switches, 2-SPDT (open/close), 250 V ac 16 A rating	HQ-008 to HQ-300
	ATS additional torque switches, 2-SPDT (open/close), 250 V ac 16 A rating	HQ-015 to HQ-300
High speed	High speed actuator (2L, 3L)	HQ-008 to HQ-300
Travel angle	EXT extension 120°, 135°, 180°, 270°, etc.	HQ-008 to HQ-300
	R reverse operation, 90±10° (0-110°) counter-clockwise to close	HQ-008 to HQ-300
Control	PIU potentiometer unit (0-1 kΩ)	HQ-008 to HQ-300
	CPT current position transmitter (4-20 mA dc)	HQ-015 to HQ-300
	PCU Proportional Control Unit (modulating), input/output: 0-10 V dc or 4-20 mA dc (duty cycle) S4 40-70%, 800-1,200 starts/hour (room temperature, average load of 50% of maximum force)	HQ-015 to HQ-300
	PROFI Registered PROFIBUS DP interface modules	HQ-008 to HQ-300
	MODBUS Modbus modules	HQ-008 to HQ-300
	CANopen CANopen modules	HQ-008 to HQ-300
Local control	LCU-B EX : LED local control unit	HQ-008 to HQ-300
	LCU-2B EX: LED local control unit (integral switch)	HQ-008 to HQ-300
Coating (color)	● Other colors, ○ Nano coating (for corrosive environment)	HQ-008 to HQ-300
Others	SPD Surge protection device (Max. 15 kW)	HQ-008 to HQ-300
	FPA1 Fire proofing actuator (1050±5°C / 50 min), FPA2 Fire proofing actuator (250±5°C / 150 min)	HQ-008 to HQ-300

Local Control Units

Local Control Unit-Z: LCU-Z

- Aluminum die-cast, compact size, and light weight
- Weatherproof IP67
- Applicable models: HQ-006 to HQ-900
- Power supply: 110/220 V ac 1-phase, 50/60 Hz, $\pm 10\%$
- LED lamp indicators

○ White : POWER ● Red : OPEN/OPENING ● ORANGE : LOCAL
● Blue : REMOTE ● Green : CLOSE/CLOSING ● Yellow : OVER TORQUE



Local Control Unit-B: LCU-B

- Aluminum die-cast, compact size, and integrated design
- Weatherproof IP67 or watertight IP68 option
- Integral starter (mechanical or electrical)
- Phase reversal protection with LED signal (yellow)
- Applicable models: HQ-008 to HQ-900
- Power supply:
 - 110/220 V ac 1-phase, 50/60 Hz, $\pm 10\%$
 - 220 to 480 V ac 3-phase, 50/60 Hz, $\pm 10\%$
- LED lamp indicators

○ White : POWER ● Red : OPEN/OPENING ● Yellow : OVER TORQUE
● Blue : REMOTE ● Green : CLOSE/CLOSING



Local Control Unit-C: LCU-C

- Aluminum die-cast, compact size, and integrated design
- Weatherproof IP67 or watertight IP68 option
- LCD monitor: digital indicators with numbers and graphs
- Separate terminal chamber
- Auto phase discriminator (easy & convenient wiring)
- Applicable models: HQ-008 to HQ-900
- Power supply:
 - 110/220 V ac 1-phase, 50/60 Hz, $\pm 10\%$
 - 220 to 480 V ac 3-phase, 50/60 Hz, $\pm 10\%$



Rechargeable Battery Pack: RBP

- Aluminum die-cast and compact size
- Emergency application in case of a power failure at site
- Applicable models:
 - HQ-008 to HQ-030, HQ-060 to HQ-300
- Power supply:
 - 110/220 V ac 1-phase, 50/60 Hz, $\pm 10\%$
 - 24 V dc
- LED lamp indicators

○ White : POWER ● Red : OPEN/OPENING ● Yellow : OVER TORQUE
● Blue : REMOTE ● Green : CLOSE/CLOSING ● GBR : BATTERY LEVEL



MODBUS / PROFIBUS

- Weatherproof IP67 or watertight IP68 option
- Additional cable entries : 4 x NPT3/8
- Integral starter (mechanical or electrical)
- Phase reversal protection with LED signal (yellow)
- Applicable models: HQ-008 to HQ-900
- Power supply:
 - 110/220 V ac 1-phase, 50/60 Hz, $\pm 10\%$
 - 220 to 480 V ac 3-phase, 50/60 Hz, $\pm 10\%$
- LED lamp indicators
 - White : POWER ● Red : OPEN/OPENING ● Yellow : OVER TORQUE
 - Blue : REMOTE ● Green : CLOSE/CLOSING



Explosion Proof Local Control Unit-B(EX): LCU-B(EX)

- Flameproof (Ex db IIB T4) / Dust ignition proof (Ex tb IIIC T135°C)
- Weatherproof IP67 or watertight IP68 option
- Applicable models: HQ-008 to HQ-300
- Power supply:
 - 110/220 V ac 1-phase, 50/60 Hz, $\pm 10\%$
 - 220 to 480 V ac 3-phase, 50/60 Hz, $\pm 10\%$
- LED lamp indicators
 - White : POWER ● Red : OPEN/OPENING ● Yellow : OVER TORQUE
 - Blue : REMOTE ● Green : CLOSE/CLOSING



Explosion Proof Local Control Unit-2B(EX): LCU-2B(EX)

- Flameproof (Ex db IIB T4) / Dust ignition proof (Ex tb IIIC T135°C)
- Separate terminal chamber
- Weatherproof IP67 or watertight IP68 option
- Applicable models: HQ-008 to HQ-300
- Additional cable entries : 5 x NPT3/4"
- Power supply:
 - 110/220 V ac 1-phase, 50/60 Hz, $\pm 10\%$
 - 220 to 480 V ac 3-phase, 50/60 Hz, $\pm 10\%$
- LED lamp indicators
 - White : POWER ● Red : OPEN/OPENING ● Yellow : OVER TORQUE
 - Blue : REMOTE ● Green : CLOSE/CLOSING



Explosion Proof MODBUS / PROFIBUS

- Flameproof (Ex db IIB T4) / Dust ignition proof (Ex tb IIIC T135°C)
- Separate terminal chamber
- Weatherproof IP67 or watertight IP68 option
- Applicable models: HQ-008 to HQ-300
- Additional cable entries : 5 x NPT3/4"
- Power supply:
 - 110/220 V ac 1-phase, 50/60 Hz, $\pm 10\%$
 - 220 to 480 V ac 3-phase, 50/60 Hz, $\pm 10\%$
- LED lamp indicators
 - White : POWER ● Red : OPEN/OPENING ● Yellow : OVER TORQUE
 - Blue : REMOTE ● Green : CLOSE/CLOSING



Dimensional Drawing

HQ-008 to HQ-120

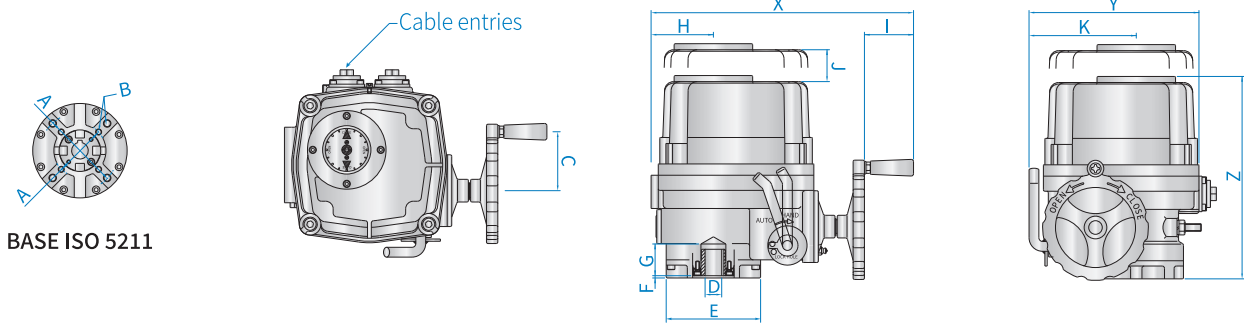

BASE ISO 5211

HQ-200 to HQ-300

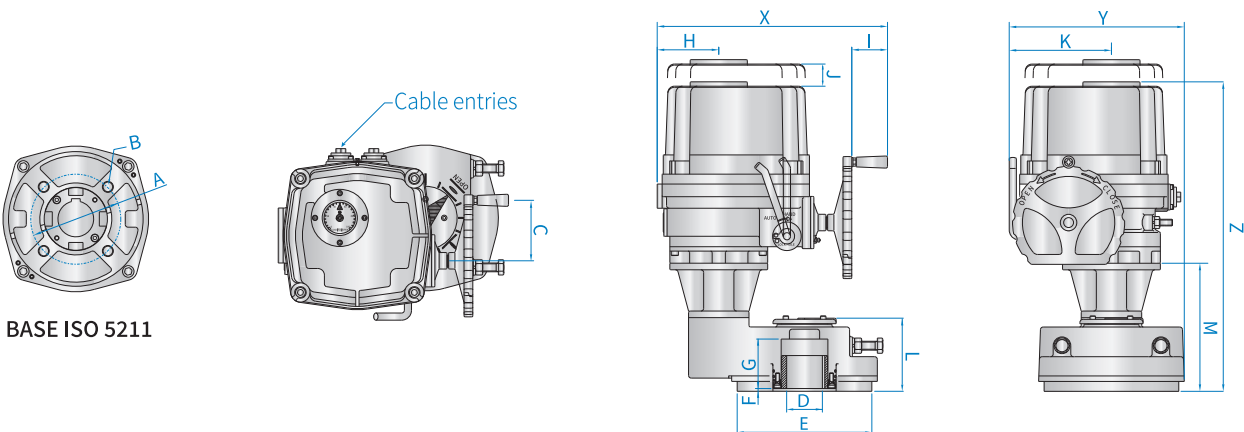

BASE ISO 5211

Dimension

unit(mm)

Model	A ISO 5211	B	C	D Max.	E	F	G	H	I	J	K	L	M	X	Y	Z
HQ-008	F07 Ø70	M8 DP12	60	20	94	3	32	57	51	40	100			265	166	235
HQ-010	F07 Ø70	M8 DP12	60	20	94	3	32	57	51	40	100			265	166	235
HQ-015	F07 / F10 Ø70 / Ø102	M8 / M10 DP12 / DP15	78	22	125	3	43	83	65	54	142			348	255	268
HQ-020	F07 / F10 Ø70 / Ø102	M8 / M10 DP12 / DP15	78	22	125	3	43	83	65	54	142			348	255	268
HQ-030	F10 / F12 Ø102 / Ø125	M10 / M12 DP15 / DP18	78	35	148	3	49	92	65	65	160			348	255	290
HQ-050	F10 / F12 Ø102 / Ø125	M10 / M12 DP15 / DP18	78	35	148	3	49	92	65	65	160			378	255	304
HQ-060	F10 / F12 Ø102 / Ø125	M10 / M12 DP15 / DP18	78	35	148	3	49	92	65	65	160			378	255	304
HQ-080	F12 / F14 Ø125 / Ø140	M12 / M16 DP18 / DP24	110	45	178	3	57	112	65	78	186			378	289	330
HQ-120	F12 / F14 Ø125 / Ø140	M12 / M16 DP18 / DP24	110	45	178	3	57	112	65	78	186			419	289	330
HQ-200	F14 or F16 Ø140 or Ø165	M16 or M20 DP24 or DP30	110	65	245	5	90	112	65	78	186	233	133	419	319	563
HQ-270	F14 or F16 Ø140 or Ø165	M16 or M20 DP24 or DP30	110	65	245	5	90	112	65	78	186	233	133	419	319	563
HQ-300	F14 or F16 Ø140 or Ø165	M16 or M20 DP24 or DP30	110	65	245	5	90	112	65	78	186	233	133	419	319	563

*Please consult the factory for the appropriate machined bushing size, as maximum bushing size can vary depending on the shape (star, key, etc.)

Dimensional Drawing

Explosion Proof HQ-008 to HQ-120

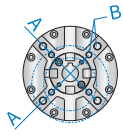

BASE ISO 5211

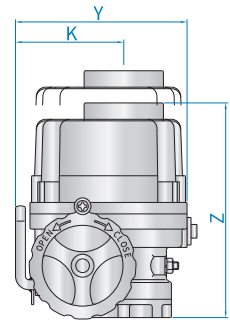
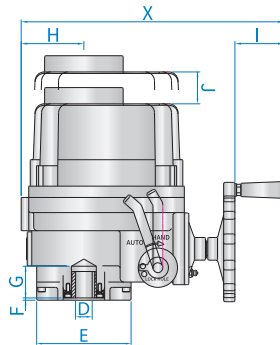
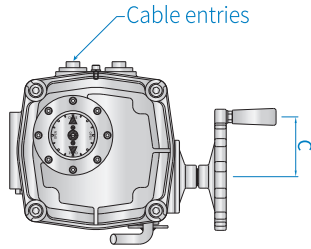

Explosion Proof HQ-200 to HQ-300

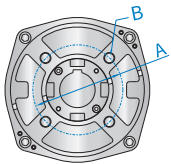

BASE ISO 5211

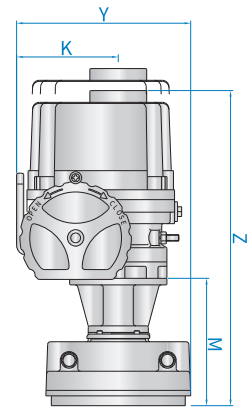
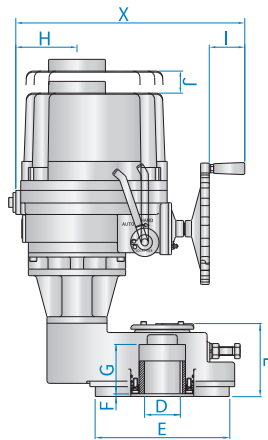
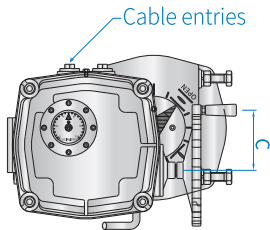

Dimension

unit(mm)

Model	A ISO 5211	B	C	D Max.	E	F	G	H	I	J	K	L	M	X	Y	Z
HQ-008	F07 Ø70	M8 DP12	60	20	94	3	32	57	51	40	100			265	166	249
HQ-010	F07 Ø70	M8 DP12	60	20	94	3	32	57	51	40	100			265	166	249
HQ-015	F07 / F10 Ø70 / Ø102	M8 / M10 DP12 / DP15	78	22	125	3	43	83	65	54	142			348	255	282
HQ-020	F07 / F10 Ø70 / Ø102	M8 / M10 DP12 / DP15	78	22	125	3	43	83	65	54	142			348	255	282
HQ-030	F10 / F12 Ø102 / Ø125	M10 / M12 DP15 / DP18	78	35	148	3	49	92	65	65	160			348	255	318
HQ-050	F10 / F12 Ø102 / Ø125	M10 / M12 DP15 / DP18	78	35	148	3	49	92	65	65	160			378	255	318
HQ-060	F10 / F12 Ø102 / Ø125	M10 / M12 DP15 / DP18	78	35	148	3	49	92	65	65	160			378	255	318
HQ-080	F12 / F14 Ø125 / Ø140	M12 / M16 DP18 / DP24	110	45	178	3	57	112	65	78	186			378	289	344
HQ-120	F12 / F14 Ø125 / Ø140	M12 / M16 DP18 / DP24	110	45	178	3	57	112	65	78	186			419	289	344
HQ-200	F14 or F16 Ø140 or Ø165	M16 or M20 DP24 or DP30	110	65	245	5	90	112	65	78	186	233	133	419	319	577
HQ-270	F14 or F16 Ø140 or Ø165	M16 or M20 DP24 or DP30	110	65	245	5	90	112	65	78	186	233	133	419	319	577
HQ-300	F14 or F16 Ø140 or Ø165	M16 or M20 DP24 or DP30	110	65	245	5	90	112	65	78	186	233	133	419	319	577

*Please consult the factory for the appropriate machined bushing size, as maximum bushing size can vary depending on the shape (star, key, etc.)

HQ-350 to HQ-400

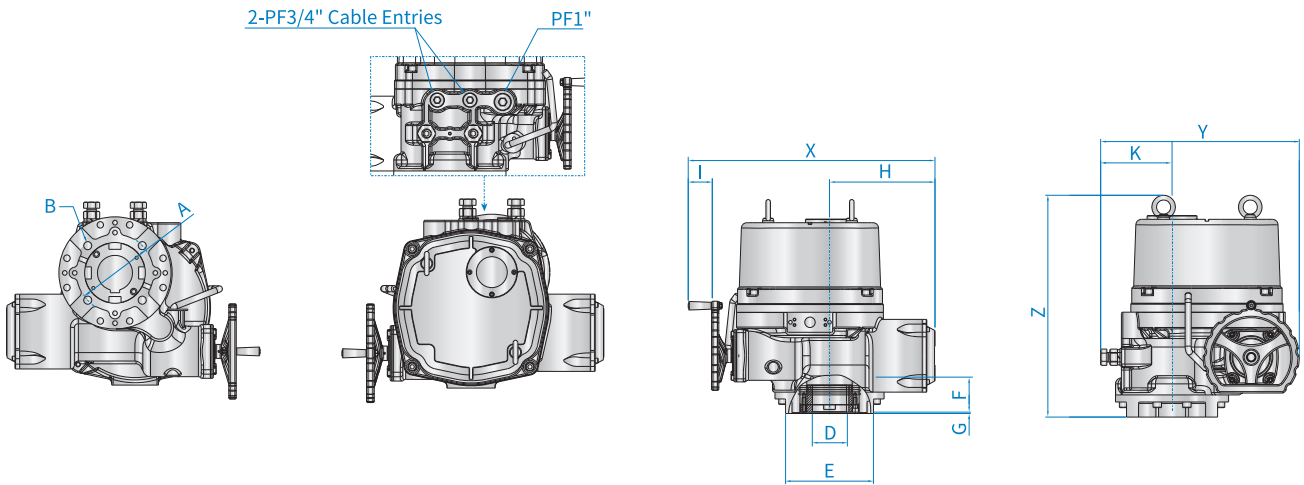

HQ-600 to HQ-900

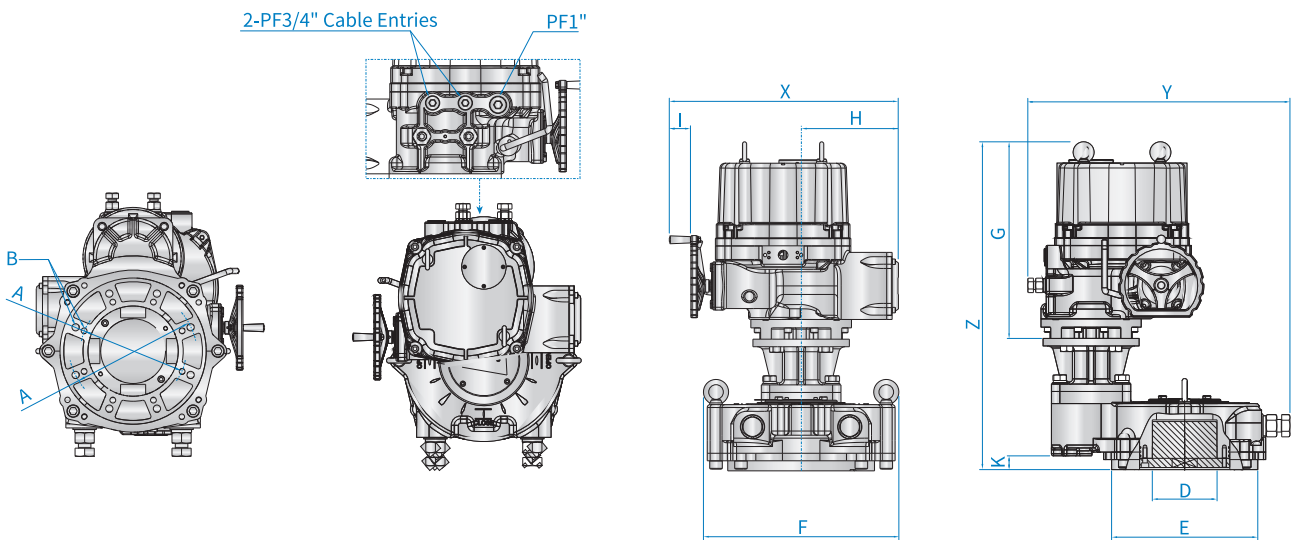

Dimension

unit(mm)

Model	A ISO 5211	B	D Max.	E	F	G	H	I	K	X	Y	Z
HQ-350	F16 Ø165	M8 DP30	75	240	77	3	232	52	152	546	422	471
HQ-400	F16 Ø165	M8 DP30	75	240	77	3	232	52	152	546	422	471
HQ-600	F25 / F30 Ø254 / Ø298	M16 / M20 DP30 / DP35	100	350	448	471	232	52	33	546	628	785
HQ-800	F25 / F30 Ø254 / Ø298	M16 / M20 DP30 / DP35	100	350	448	471	232	52	33	546	628	785
HQ-900	F25 / F30 Ø254 / Ø298	M16 / M20 DP30 / DP35	100	350	448	471	232	52	33	546	628	785

Dimensional Drawing

Local Control Unit-Z: LCU-Z

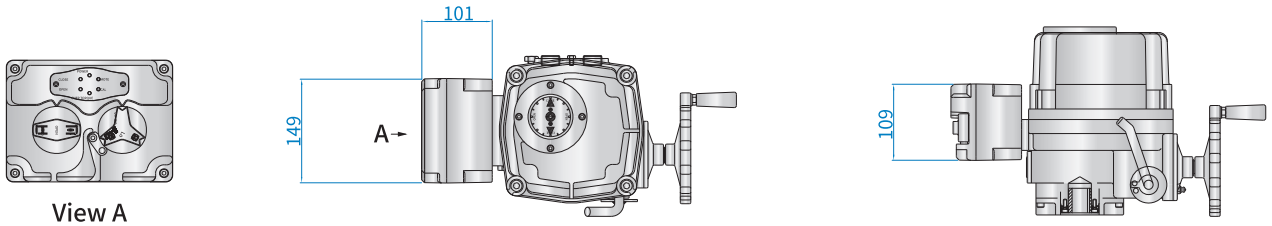

Local Control Unit-B: LCU-B

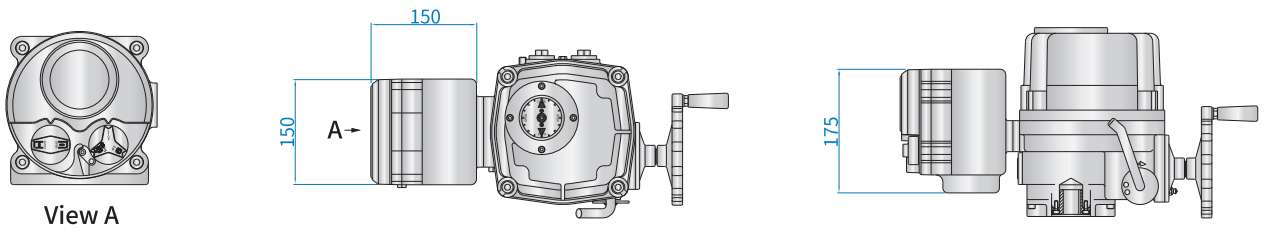

Local Control Unit-C: LCU-C

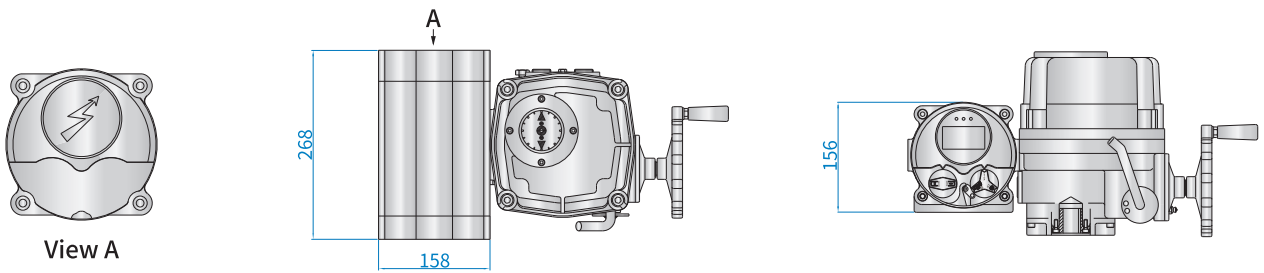

Rechargeable Battery Pack: RBP

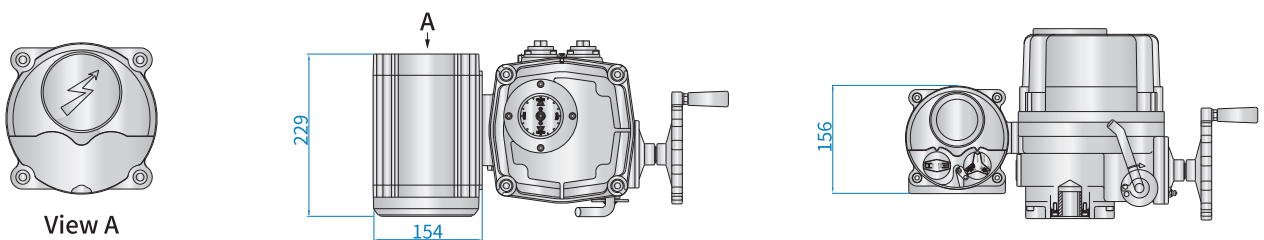

MODBUS / PROFIBUS

4 x NPT1/2"

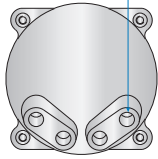

View A

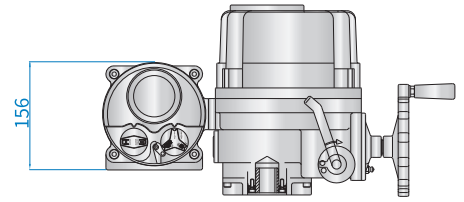
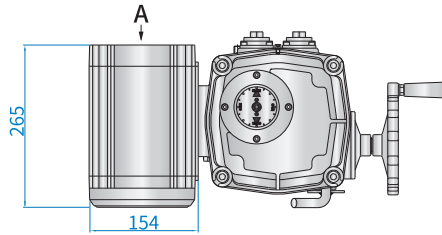

Explosion Proof Local Control Unit-B(EX): LCU-B(EX)

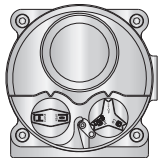

View A

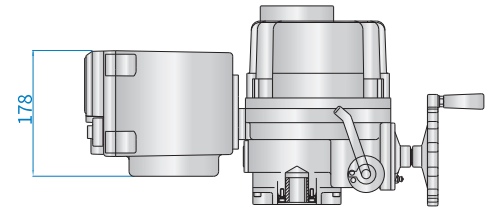
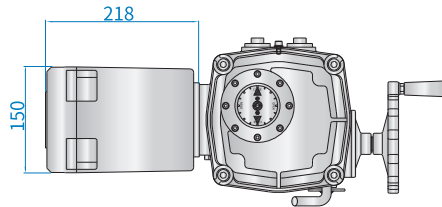

Explosion Proof Local Control Unit-2B(EX): LCU-2B(EX)

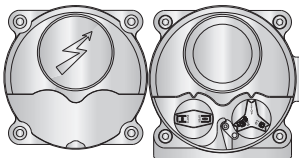

View A

View B

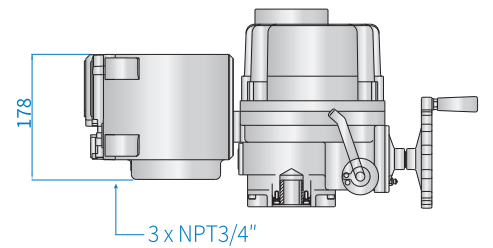
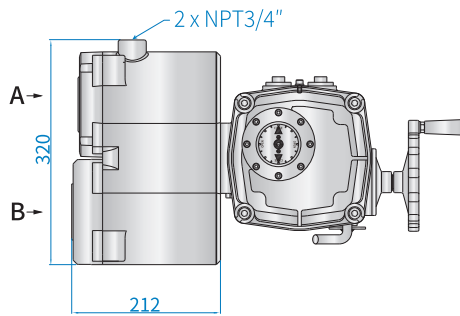

Explosion Proof MODBUS / PROFIBUS

4 x NPT1/2"

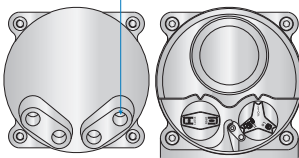

View A

View B

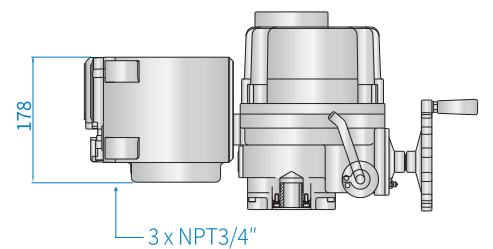
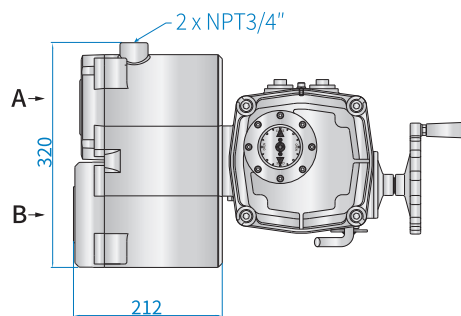

HQ-004 Ordering Code

Example:

HQ-004 ¹06 ²0 ³0 ⁴0 ⁵0 ⁶0

1

Color	
06	Red (RAL 3001)
16	Blue (RAL 5005)
11	Yellow (RAL 1033)
21	Grey (RAL 7046)
25	Light grey (RAL 7035)
33	Green (RAL 6034)
SP	Other colors
NC	Nano Coating

2

Cable entry	
0	PG11
M	M20

3

Power	
0	1-Phase 85-265 V ac / 24 V dc
1	12 V dc

4

Speed	
0	Standard
H	HSA: High Speed Actuator

5

Cable length	
0	1.2m (standard)
1	3m
2	6.2m
3	10m

6

Base (flange)	
0	ST11 (Star 11)
1	ST14 (Star 14)

HQ-006 Ordering Code

Example:

HQ-006 ¹06 ²0 ³0 ⁴0 ⁵00 ⁶0 ⁷0 ⁸0

1

Color	
06	Red (RAL 3001)
16	Blue (RAL 5005)
11	Yellow (RAL 1033)
21	Grey (RAL 7046)
25	Light grey (RAL 7035)
33	Green (RAL 6034)
SP	Other colors
NC	Nano Coating

2

Enclosure	
0	General purpose
A	Flameproof: Ex d IIB

3

Cable entry	
0	2 x PG13.5
P	2 x PF1/2"
N	2 x NPT1/2"
M	2 x M20

4

Power	
0	1-Phase 110/220 V ac
1	24 V dc
2	24 V ac/dc

5

Local Control Unit	
00	N/A
D0	Local Control Unit D: LCU-D
D1	Local Control Unit Z: LCU-Z

6

Control	
0	On-off
P	PIU: Potentiometer unit (0-1 kΩ)
C	CPT: Current Position Transmitter (output: 4-20 mA dc)
M	PCU: Proportional Control Unit (input/output: 0 - 10 V dc or 4 - 20 mA dc)

7

Communication	
0	N/A
M	Modbus

8

IP Rating	
0	IP67 NEMA 4, 4X
1	IP68 (10 m 72 hr)

HQ-008 to HQ-900 Ordering Code

Example:

HQ- ¹015 ²06 ³0 ⁴00 ⁵0 ⁶0 ⁷0 ⁸0 ⁹00 ¹⁰0 ¹¹0 ¹²0 ¹³0 ¹⁴0

1 Model	
008	HQ-008
010	HQ-010
015	HQ-015
020	HQ-020
030	HQ-030
050	HQ-050
060	HQ-060
080	HQ-080
120	HQ-120
200	HQ-200
270	HQ-270
300	HQ-300
350	HQ-350
400	HQ-400
600	HQ-600
800	HQ-800
900	HQ-900

2 Color	
06	Red (RAL 3001)
16	Blue (RAL 5005)
11	Yellow (RAL 1033)
21	Grey (RAL 7046)
25	Light grey (RAL 7035)
33	Green (RAL 6034)
SP	Other colors
NC	Nano Coating

3 Enclosure	
0	General purpose
A	Flameproof: Ex db IIB
T	Dust ignition proof: Ex tb IIIC

4 Local Control Unit	
00	N/A
A0	Local Control Unit-Z: LCU-Z
A1	Local Control Unit-B: LCU-B
B0	Local Control Unit-C: LCU-C
D0	Rechargeable Battery Pack: RBP
E0	Explosion proof Local Control Unit-B: LCU-B(EX)
E1	Explosion proof Local Control Unit B: LCU-2B(EX)

5 Control	
0	On-off
P	PIU: Potentiometer unit (0-1 kΩ)
C	CPT: Current Position Transmitter (output: 4-20 mA dc)
M	PCU: Proportional Control Unit (input/output: 0 – 10 V dc or 4 – 20 mA dc)

6 Cable entry	
00	2 x PF3/4"
01	2 x NPT3/4"
02	2 x M25
03	2 x M20
14	2 x PF3/4" + PF1"

7 Speed	
0	Standard
1	High speed, 2L
2	High speed, 3L

8 Rotation	
0	90° CW to CLOSE (standard)
1	R: 90° CCW to CLOSE
2	EXT: > 90° CW to CLOSE

9 Power	
10	1-Phase 100V
11	1-Phase 110V
12	1-Phase 200V
13	1-Phase 220V
14	1-Phase 240V
30	3-Phase 220V
31	3-Phase 380V
32	3-Phase 400V
33	3-Phase 420V
34	3-Phase 440V
35	3-Phase 460V
36	3-Phase 480V
D1	12V dc
D2	24V dc
D3	24V ac/dc

10 Communication	
0	N/A
M	Modbus
P	Profibus

11 Additional S/W	
0	N/A
1	ALS: +2-SPDT (limit s/w)
2	ATS: +2-SPDT (torque s/w)
3	ALS+ATS: +2x2-SPDT

12 Temperature	
0	Standard: -20 to +70 °C
	Flameproof: -20 to +60 °C
L	Low temperature: -60 to +60 °C (EAC)

13 IP Rating	
0	IP67
1	IP68 (10 m 72 hr)

14 Other Options	
0	N/A
F	FPA: Fire Proofing Actuator

Heavy-duty Pneumatic Actuator

ET Series

Features

- Safe and reliable operation
- Quarter-turn (ETS) or linear (ETL) valve applications
- Wide range of torque outputs
- Available in either double acting or spring return configurations
- Versatile modular design
- MSS or ISO flange standard
- A complete customized solution with pneumatic accessories attached

Description

Providing safe and reliable operation, the ET Series heavy-duty pneumatic actuators are designed for large, high torque quarter-turn valve applications (ETS) as well as linear valve applications (ETL).

The quarter-turn ET Series actuators are available in both single acting (spring return) or double acting configurations

Wide range of application

With reliable and stable operation, the ET Series is used in many industries:

- Oil & gas
- Power plant
- Chemical & petrochemical
- Water
- Marine & shipbuilding

Complete customized solution

With years of valve automation experience and manufacturing expertise since 1991, HKC provides not only the actuators but also actuators with pneumatic accessories, a complete customized solution to the needs of our customers.

Inherently Safe Design

The fully welded spring module of the ET Series actuators has been designed to be inherently safe. Located inside the spring case, the springs are held by the piston and piston needle, hence removing the possibility of accidental release of spring force. The different springs may be used to yield different torque outputs.

Robust and Reliable Design

The ET Series actuators are robustly designed to have thick and solid components so it can provide safe and reliable operation with long actuator life. The external surfaces are coated to protect from harsh and corrosive environment while the internal components are permanently lubricated to provide low friction.

Versatile Modular Design

The ET Series modular design allows easy assembly and disassembly of its components to meet a variety of applications. The combination of different size of pneumatic cylinder and yoke, along with different size of springs, results in different torque characteristics, all of which can be easily configured, if necessary, to give optimum torque outputs.



Certificates and approvals

- PED
- SIL 2 (SC 3)
- EAC
- RINA type approval



Specification

Standard Specification

Material	Steel alloy & epoxy-polyurethane coated
Torque range	495 - 250,000 Nm
Operating pressure	3 - 8 bar
Travel angle	0-90°
Ambient temperature	-20 to +80 °C
Manual operation	N/A
Travel stoppers	±5° adjustable travel stops
Coating (color)	● Traffic Red (Munsell No. 6.6R 4.5/13.2)

Optional Specification

Ambient temperature	LT: Low Temperature: -60 to +60 °C, EAC HT: High temperature: -20 to +100 °C
Manual operation	JS: Jack screw manual handwheel HO: Hydraulic override
Ambient temperature	-20 to +80 °C
Coating (color)	● Other colors , ○ Nano coating
Others	Compact air tubing

Torque

Model	Max. Torque (Nm)
ETS-050	1,000
ETS-065	3,500
ETS-085	9,500
ETS-100	14,000
ETS-130	35,000
ETS-160	40,000
ETS-160w	59,000
ETS-200w	150,000
ETS-270w	250,000

ETS Design Features

NAMUR Standard

The ET Series provides NAMUR standard interface for quick and convenient mounting of pneumatic accessories, such as positioners and limit switch boxes.

Symmetric Type Yoke

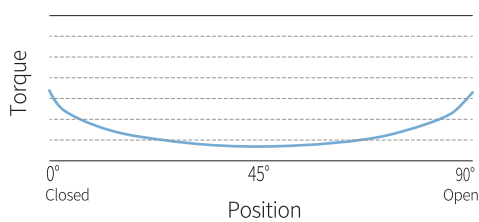

Safe Position Guide Bar

The ET Series is designed to minimize friction under low air pressure and position guide bars inside the cylinder are designed to maintain smooth & steady operation. The ET Series prevents any transformation of spring retainer and piston by using anti-abrasive engineering plastic bushing.

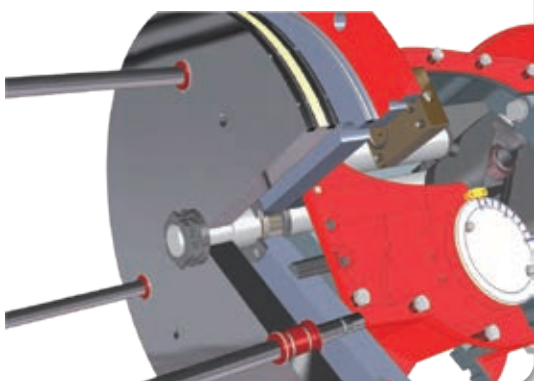

Compact Air Tubing Type

Optional built-in air pipe and in/out air blocks on both end of cylinder covers provide simple and easy installation of accessories, such as solenoid valve, air set, and etc.

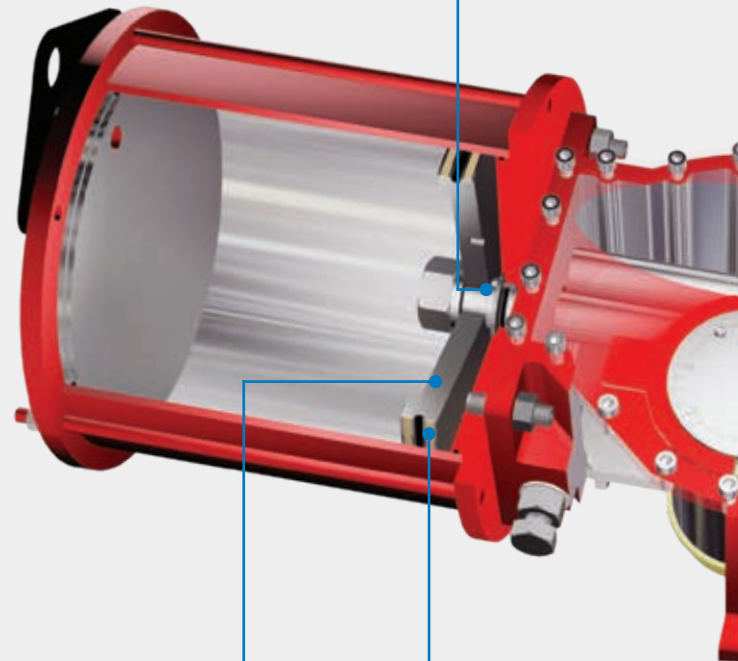
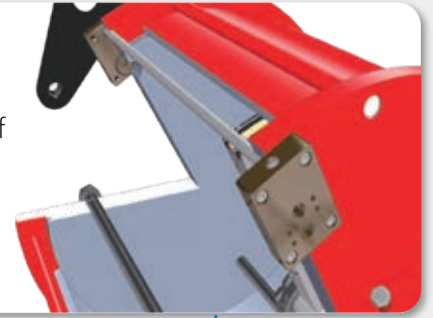

Piston Guide Ring

High quality back-up ring prevents any leakage, ensures high performance of piston and extends piston's operating lifespan.



■ Alignment of Modules

The center ring ensures accurate alignment between housing and cylinder case.

■ Replaceable Bearing

Surface heat treated yoke, bearings and pins extend the actuator's lifespan with low friction and permanent lubrication.



■ Alignment of Modules

Spring rod guide holder and bushing inside the spring case maintain safe and reliable operation of the spring module.

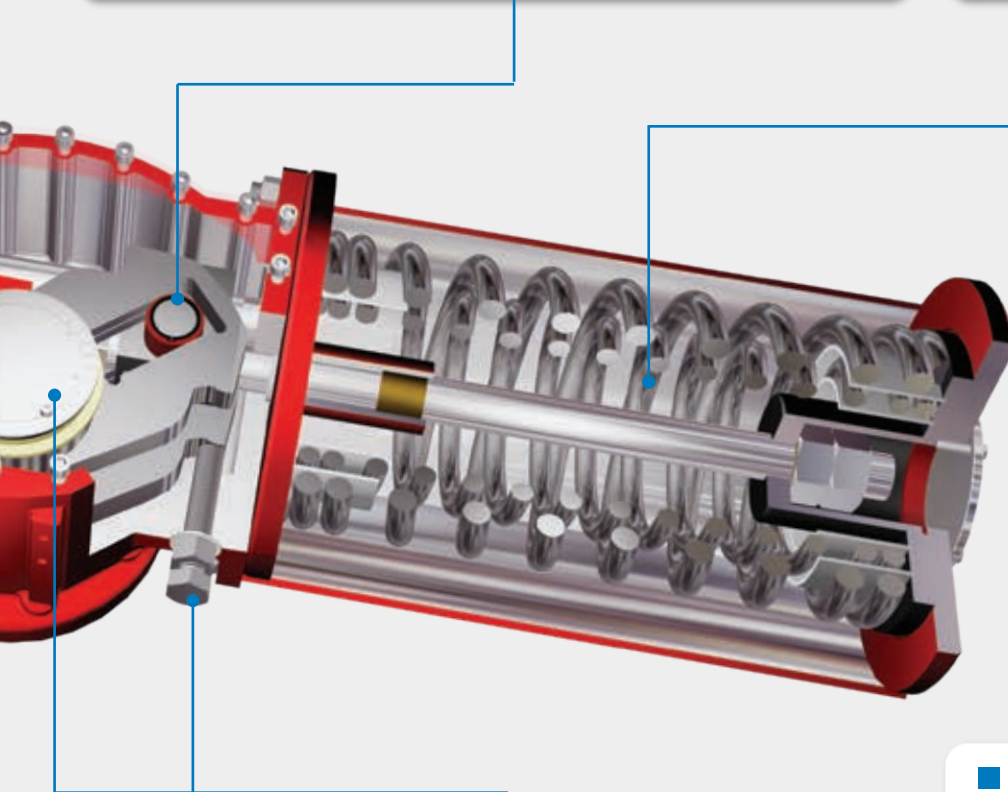
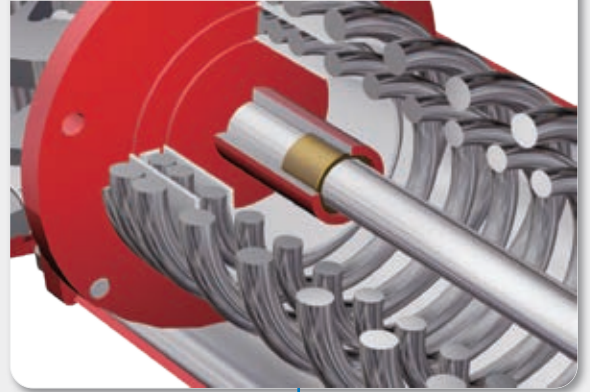

■ Travel Stops / Indicator

Each two travel stops can be set to $\pm 5^\circ$ of adjustment allowing -5° to 95° travel range. With the simple and clear indicator, the current position of the actuator can be easily determined.

■ Manual Overrides

Optional hydraulic / jack screw overrides can be incorporated in accordance with the customer's requirements.



Hydraulic Override



Jack Screw Override

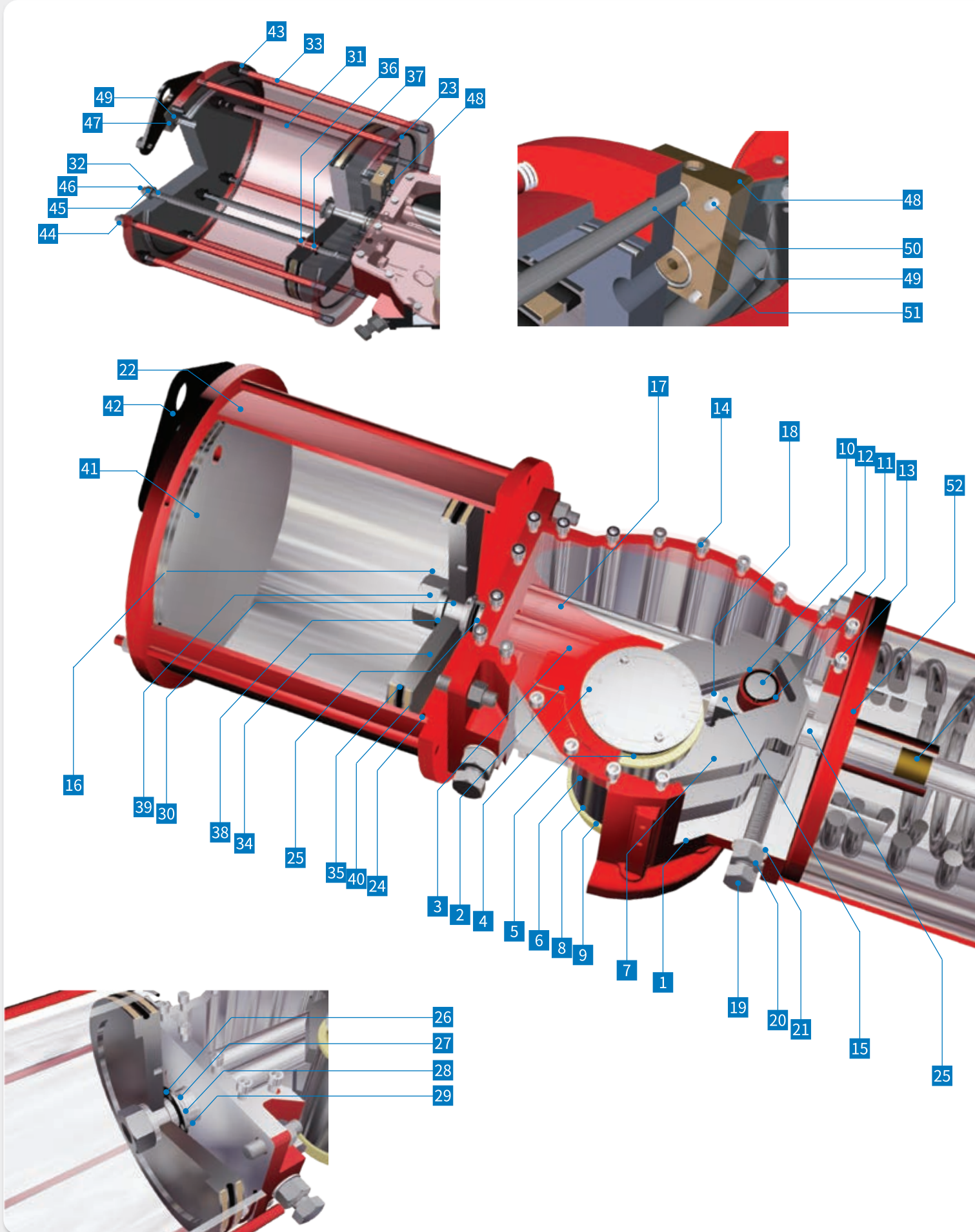



* Recommended spare parts

No.	Description	Material
1	Housing	Ductile iron
2	Housing cover	Ductile iron
3	Position needle	Alloy steel
4	Position indicator	Stainless steel
* 5	Upper bushing o-ring	NBR
6	Upper bushing	BSC
7	Yoke	Alloy steel
* 8	Low bushing o-ring	NBR
9	Low bushing	BSC
10	Snap-ring	Alloy steel
11	Slide bearing	Alloy steel
12	Slide pin	Alloy steel
13	Cover fixed pin	Alloy steel
14	Cover bolt	Alloy steel
15	Slide block	Alloy steel
16	Piston rod lock nut	Alloy steel
17	Guide bar	Alloy steel
18	Guide bushing	DU dry bushing
19	Travel stopper bolt	Alloy steel
20	Travel stopper nut	Alloy steel
21	Travel stopper washer	Alloy steel
22	Cylinder	Alloy steel
23	Cover o-ring	NBR
* 24	Center-ring	Alloy steel
25	Piston rod bushing	DU dry bushing
* 26	Rod seals	PTFE
* 27	Rod seals o-ring	NBR
28	Piston rod o-ring retainer	Alloy steel
29	Seals retainer bolt	Alloy steel
30	Piston rod	Alloy steel
31	Piston guide bar	Alloy steel
* 32	Piston guide bar o-ring	NBR
33	Tie bolt	Alloy steel
34	Piston	Alloy steel
* 35	Piston o-ring	NBR
* 36	Piston guide bushing	Engineering plastic
* 37	Piston guide bar bushing o-ring	NBR
38	Rod washer	Alloy steel
39	Rod lock nut	Alloy steel
* 40	Back-up ring	PTFE
41	Cylinder end cover	Alloy steel
42	Lift plate	Alloy steel
43	Tie bolt washer	Alloy steel
44	Tie bolt nut	Alloy steel
45	Piston guide bar nut	Alloy steel
46	Piston guide bar bolt	Alloy steel
47	End air plate	ALM
48	Front air plate	ALM
49	Air plate o-ring	NBR
50	Air plate bolt	Alloy steel
51	Air pipe	Stainless steel
52	Spring case front cover	Alloy steel
53	Spring rod guide bushing	Engineering plastic
54	Spring case	Carbon steel
55	Spring	Alloy steel
56	Spring rod	Alloy steel
57	Spring retainer	Alloy steel
58	Rod adjust nut	Alloy steel
59	Spring case end cover	Alloy steel
60	Cap	Alloy steel
61	Cap bolt	Alloy steel

Versatile Modular Design

The ET Series provides versatile modular configuration. The following removable modules can be easily added, removed and altered; converting from a single-acting to a double-acting and vice versa, or adding a hydraulic manual override can be done after installation and without the need for disassembly of other modules.

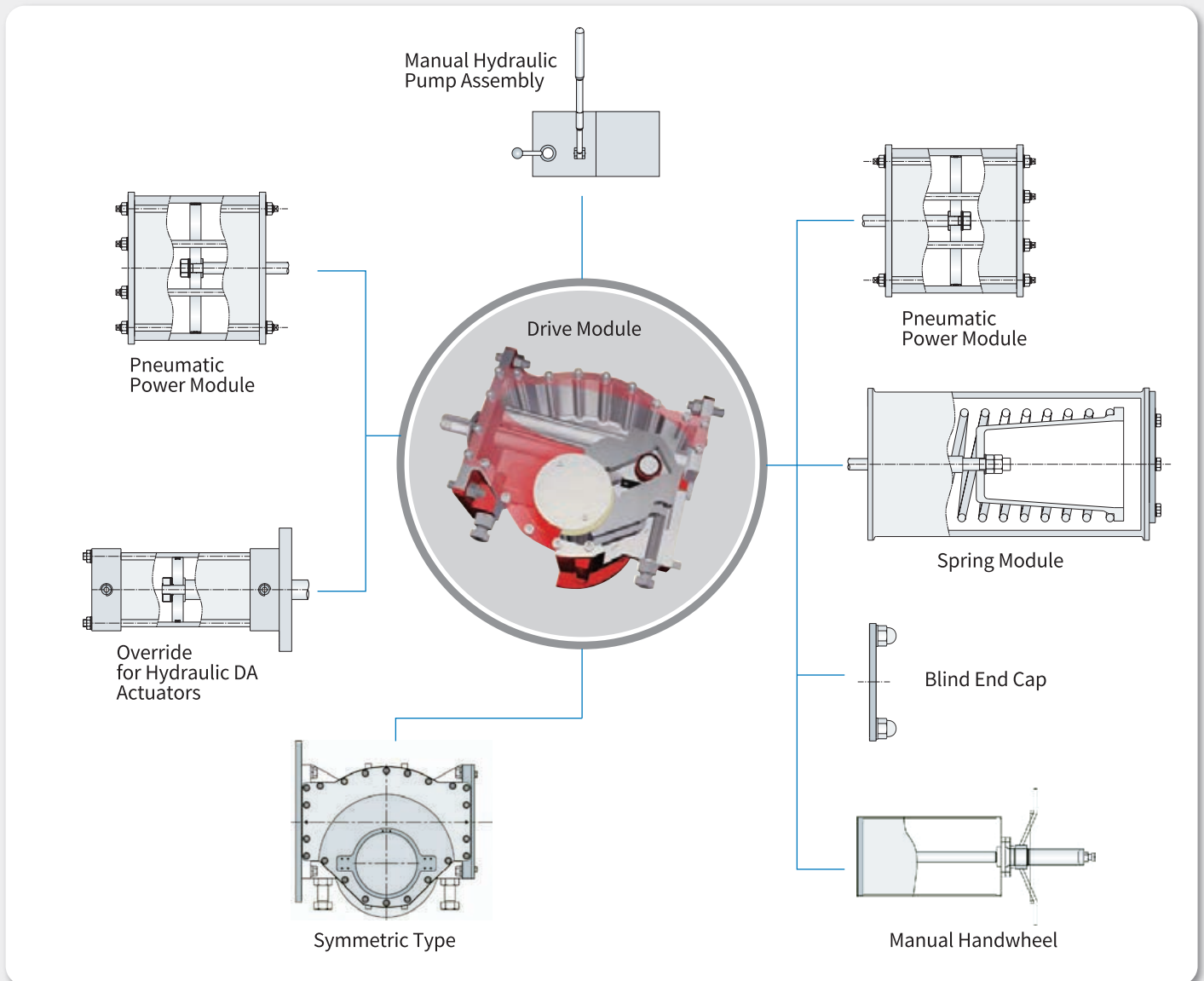

ETS Mounting Position

← Flow Direction ←

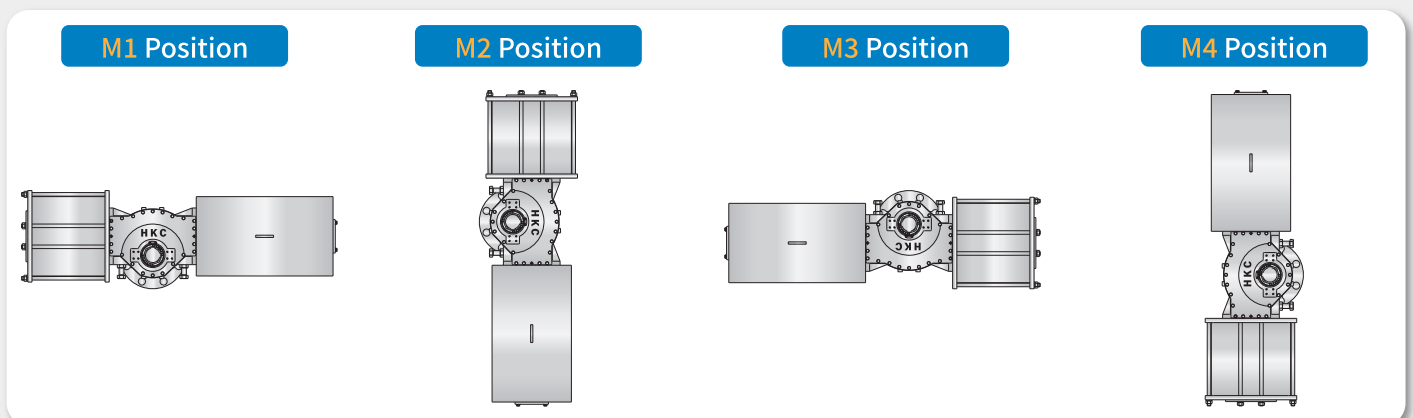

ETL Parts List

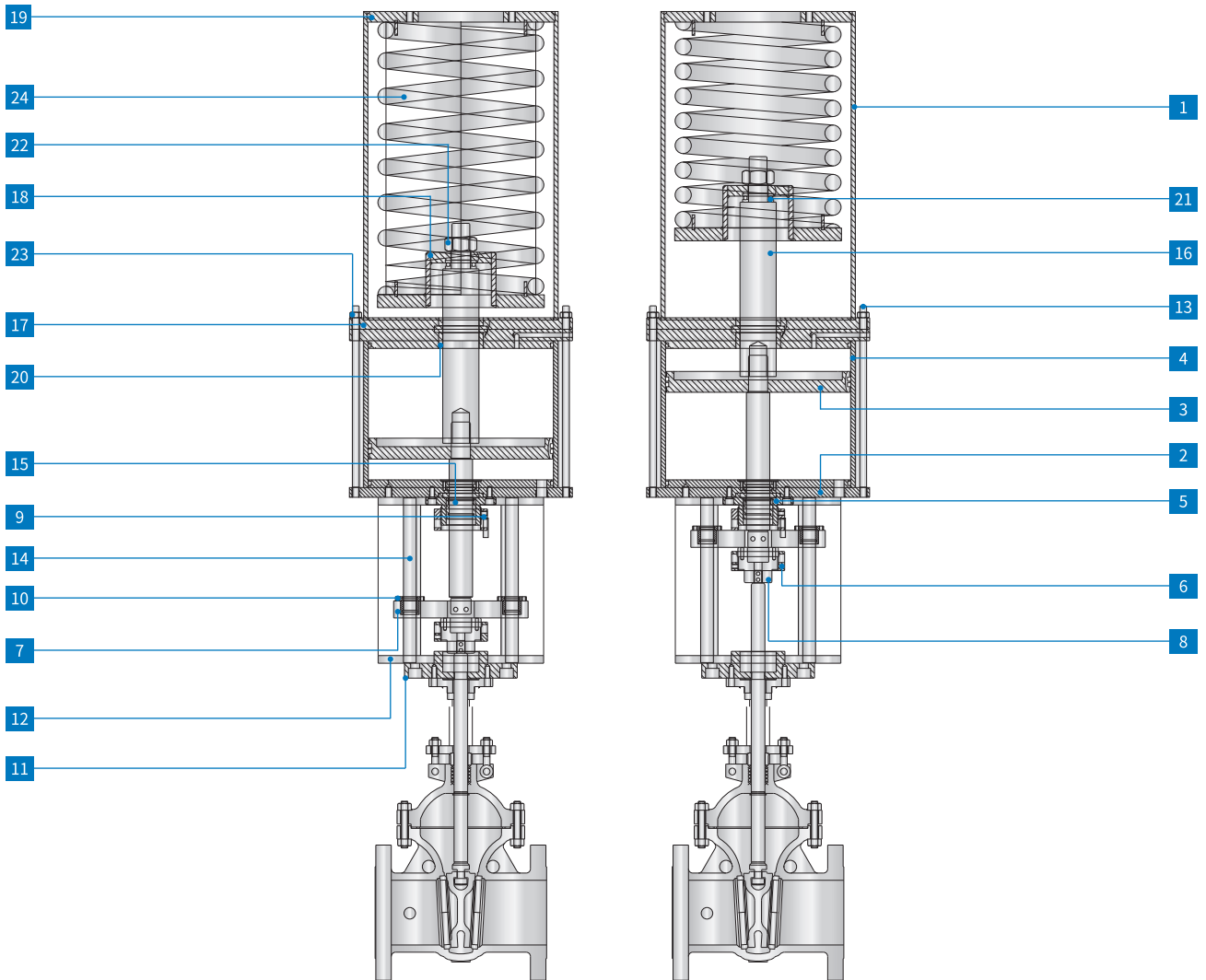

No.	Description	Material
1	Spring cylinder	SB410
2	Front cover	S45C
3	Piston	SS41
4	Cylinder	S45C
5	Front cover flange	S45C
6	Stopper Nut-A	S45C
7	Yoke	S45C
8	Stopper	S45C
9	Stopper Nut-B	S45C
10	LM Bushing	PBC
11	Body Flange	S45C
12	Body	SS400

No.	Description	Material
13	Tie bolt	S45C
14	Guide bar	S45C
15	Guide bar bushing	-
16	Piston rod	S45C
17	Cylinder end cover	S45C
18	Spring retainer	S45C
19	Spring end cover	S45C
20	Guide bush	PBC
21	Thrust bearing	Ally steel
22	Nut	Alloy steel
23	Nut	Alloy steel
24	Out spring	SEA9254

Ordering Code

Example:

ETS - ¹085 ²SR - ³385 ⁴C ⁵8 ⁶10 ⁷HO

1

Model	
050	ETS-050
065	ETS-065
085	ETS-085
100	ETS-100
130	ETS-130
160	ETS-160
160w	ETS-160w
200w	ETS-200w
270w	ETS-270w

2

Acting Type	
DA	Double acting
SR	Spring return (single acting)

3

Cylinder	
130	130
150	150
180	180
200	200
235	235
250	250
300	300
335	335
385	385
435	435
:	:
885	885
935	935
985	985
1050	1050
1150	1150
1200	1200
1250	1250

4

Fail Position	
	N/A (double acting)
C	Fail close
O	Fail open

5

Spring No.	
	N/A (double acting)
1	1
2	2
3	3
4	4
5	5
6	6
7	7
8	8
9	9
10	10

6

Color	
10	● Traffic Red (Munsell No. 6.6R 4.5/13.2)
SP	● Other colors
NC	○ Nano Coating

7

Manual operation	
00	N/A
JS	Jack Screw
HO	Hydraulic Override



Pneumatic Actuator HP Series

Features

- Safe and reliable operation
- Rack & Pinion (HP-035 to HP-210) and Scotch Yoke (HP-211 & HP-212) design
- Wide range of torque outputs
- Available in either double acting or spring return configurations
- NAMUR and ISO flange standard
- A complete customized solution with pneumatic accessories attached

Description

Providing safe and reliable operation, the HP Series pneumatic actuators are designed for small to medium sized quarter-turn valve applications.

The quarter-turn HP Series actuators are available in both single acting (spring return) or double acting configurations

Wide range of application

With reliable and stable operation, the HP Series is used in many industries:

- Oil & gas
- Power plant
- Chemical & petrochemical
- Water
- Marine & shipbuilding

Safe and Reliable Operation

The HP Series is designed to have a thick aluminium body so that it can safely operate at high operating pressure and provides efficient performance with long actuator life. The external surfaces are anodized to protect from harsh and corrosive environment. For usage in severe corrosive environments, polyester powder coating and/or nano-coating can be further applied to the HP Series to enhance corrosion protection.

Complete customized solution

With years of valve automation experience and manufacturing expertise since 1991, HKC provides not only the actuators but also actuators with pneumatic accessories, a complete customized solution to the needs of our customers.

Certificates and approvals

- PED
- SIL 2 (SC 3)
- EAC
- RINA type approval





Specification

Standard Specification

Material	High grade aluminium alloy
Design	Rack & pinion (HP-035 to HP-210) and scotch yoke (HP-211 to HP-212)
Operating pressure	2.5 to 8 bar
Travel angle	0 to 90 ± 5° (with travel stoppers)
Ambient temperature	-20 to +80 °C
Lubrication	Grease moly (EP type)
Body	Soft anodized
Coating (cover color)	● Black (RAL 9005), ● Red (RAL 3001), ● Blue (RAL 5005), ● Yellow (RAL 1033)

Optional Specification

Travel angle	135° 0 to 135° (±5° with travel stoppers) (HP-075D, HP-100D, HP-125D, HP-145D, HP-180D, HP-200D only)
	3P 0 to 45 to 90° (±5° with travel stoppers) (HP-075D only)
	Side 0 to 60°, 0 to 120°, etc. (±5° with travel stoppers)
Ambient temperature	LT low temperature: -40 to +80 °C
	HT high temperature: -20 to +150 °C
Body	Dark(AD) hard anodized
Coating (cover color)	● Polyester powder coating or epoxy-polyurethane coating, ○ Nano coating (for corrosive environment)
	● Other colors, ○ Nano coating (for corrosive environment)

Torque Diagram

Rack & Pinion

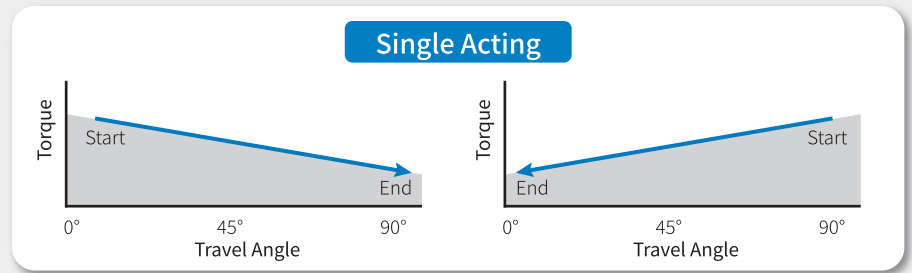
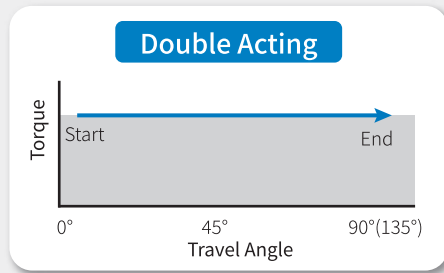

Scotch Yoke

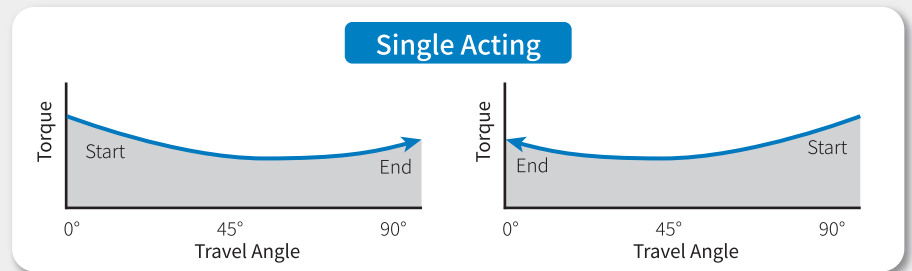
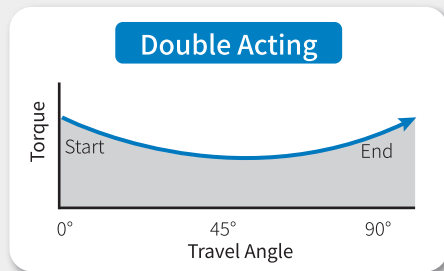

Performance

Rack & Pinion

Double Acting (Torque: Nm)

Model	135°	Air Supply									
		2.5 bar	3 bar	3.5 bar	4 bar	4.5 bar	5 bar	5.6 bar	6 bar	7bar	8 bar
HP-035D		3.8	4.5	5.3	6.0	6.8	7.5	8.3	9.0	10.5	12.0
HP-050D		8.3	10.0	11.7	13.3	15.0	16.6	18.3	20.0	23.3	26.6
HP-063D		15.0	17.9	20.9	23.9	26.9	29.9	32.9	35.9	41.9	47.0
HP-066D		20.9	25.1	29.3	35.5	37.7	41.9	46.1	50.3	58.6	67.0
HP-075D	✓	28.7	34.5	40.2	45.9	51.7	57.4	63.2	68.9	80.4	92.0
HP-088D		46.1	55.3	64.5	73.7	83.0	92.2	101.4	110.6	129.0	147.0
HP-100D	✓	68.1	81.9	95.5	109.2	122.8	136.5	150.1	163.8	191.1	214.0
HP-115D		107.5	129.0	150.5	172.0	193.5	215.0	236.5	258.0	301.0	344.0
HP-125D	✓	138.5	166.2	190.4	221.7	249.4	277.1	304.8	332.5	387.9	443.3
HP-145D	✓	217.5	261.0	304.5	348.0	391.5	435.0	478.5	522.0	609.0	696.0
HP-160D		283.7	340.5	397.2	454.0	510.7	567.4	624.2	680.9	794.4	908.0
HP-180D	✓	382.8	459.4	536.0	612.5	689.1	765.7	842.2	918.8	1071.9	1225.0
HP-200D	✓	531.7	638.0	744.4	850.7	957.1	1063.4	1169.8	1276.1	1488.8	1701.5
HP-210D		586.9	704.3	821.6	939.0	1056.4	1173.8	1291.2	1408.5	1643.3	1878.1

Single Acting (Torque: Nm)

Air supply		2.5 bar		3 bar		3.5 bar		4 bar		4.5 bar		5 bar		5.6 bar		6 bar		7 bar		8 bar		Spring		
Model	No. of Spring	0	90	0	90	0	90	0	90	0	90	0	90	0	90	0	90	0	90	0	90	0	90	
		Start	End	Start	End	Start	End	Start	End	Start	End	Start	End	Start	End	Start	End	Start	End	Start	End	Start	End	
HP-050S	05	4.9	3.4	6.6	5.1	8.3	6.8	9.9	8.4	11.6	10.1	13.2	11.7	14.9	13.4							4.9	3.4	
	06	4.3	2.5	6.0	4.2	7.7	5.9	9.3	7.5	11.0	9.2	12.6	10.8	14.3	12.5	16.0	14.2					5.8	4.0	
	07	3.6	1.5	5.3	3.2	7.0	4.9	8.6	6.5	10.3	8.2	11.9	9.8	13.6	11.5	15.3	13.2	18.6	16.5			6.8	4.7	
	08				4.6	2.2	6.3	3.9	7.9	5.5	9.6	7.2	11.2	8.8	12.9	10.5	14.6	12.2	17.9	15.5			7.8	5.4
	09						5.6	2.9	7.2	4.5	8.9	6.2	10.5	7.8	12.2	9.5	13.9	11.2	17.2	14.5	20.5	17.8	8.8	6.1
	10								6.6	3.6	8.3	5.3	9.9	6.9	11.6	8.6	13.3	10.3	16.6	13.6	19.9	16.9	9.7	6.7
	11										7.6	4.3	9.2	5.9	10.9	7.6	12.6	9.3	15.9	12.6	19.2	15.9	10.7	7.4
	12														10.2	6.6	11.9	8.3	15.2	11.6	18.5	14.9	11.7	8.1

Air supply		2.5 bar		3 bar		3.5 bar		4 bar		4.5 bar		5 bar		5.6 bar		6 bar		7 bar		8 bar		Spring	
Model	No. of Spring	0	90	0	90	0	90	0	90	0	90	0	90	0	90	0	90	0	90	0	90	0	90
		Start	End	Start	End	Start	End	Start	End	Start	End	Start	End	Start	End	Start	End	Start	End	Start	End	Start	End
HP-063S	05	9.5	6.6	12.4	9.5	15.4	12.5	18.4	15.5	21.4	18.5	24.4	21.5	27.4	24.5							8.4	5.5
	06	8.3	4.9	11.2	7.8	14.2	10.8	17.2	13.8	20.2	16.8	23.2	19.8	26.2	22.8	29.2	25.8					10.1	6.7
	07	7.2	3.2	10.9	6.1	13.1	9.1	16.1	12.1	19.1	15.1	22.1	18.1	25.1	21.1	28.1	24.1	34.1	30.1			11.8	7.8
	08			9.0	4.4	12.0	7.4	15.0	10.4	18.0	13.4	21.0	16.4	24.0	19.4	27.0	22.4	33.0	28.4			13.5	8.9
	09					10.9	5.7	13.9	8.7	16.9	11.7	19.9	14.7	22.9	17.7	25.9	20.7	31.9	26.7	37.0	31.8	15.2	10.0
	10							12.8	7.0	15.8	10.0	18.8	13.0	21.8	16.0	24.8	19.0	30.8	25.0	37.0	30.1	16.9	11.1
	11									14.7	8.3	17.7	11.3	20.7	14.3	23.7	17.3	29.7	23.3	34.8	28.4	18.6	12.2
	12														19.6	12.7	22.6	15.7	28.6	21.7	33.7	26.8	20.2
HP-066S	05	13.3	8.9	17.5	13.1	21.7	17.3	25.9	21.5	30.1	25.7	34.3	29.9	38.5	34.1							12.0	7.6
	06	11.8	6.5	16.0	10.7	20.2	14.9	24.4	19.1	28.6	23.3	32.8	27.5	37.0	31.7	41.2	35.9					14.4	9.1
	07			14.5	8.3	18.7	12.5	22.9	16.7	27.1	20.9	31.3	25.1	35.5	29.3	39.7	33.5	48.0	41.8			16.8	10.6
	08			13.0	5.9	17.2	10.1	21.4	14.3	25.6	18.5	29.8	22.7	34.0	26.9	38.2	31.1	46.5	39.4			19.2	12.1
	09					15.6	7.7	19.8	11.9	24.0	16.1	28.2	20.3	32.4	24.5	36.6	28.7	44.9	37.0	53.3	45.4	21.6	13.7
	10							18.3	9.5	22.5	13.7	26.7	17.9	30.9	22.1	35.1	26.3	43.4	34.6	51.8	43.0	24.0	15.2
	11									21.0	11.3	25.2	15.5	29.4	19.7	33.6	23.9	41.9	32.2	50.3	40.6	26.4	16.7
	12														27.9	17.3	32.1	21.5	40.4	29.8	48.8	38.2	28.8
HP-075S	05	17.6	11.4	23.4	17.2	29.1	22.9	34.8	28.6	40.6	34.4	46.3	40.1	52.1	45.9							17.3	11.1
	06	15.4	7.9	21.2	13.7	26.9	19.4	32.6	25.1	38.4	30.9	44.1	36.6	49.9	42.4	55.6	48.1					20.8	13.3
	07	13.2	4.5	19.0	10.3	24.7	16.0	30.4	21.7	36.2	27.5	41.9	33.2	47.7	39.0	53.4	44.7	64.9	56.2			24.2	15.5
	08			16.8	6.8	22.5	12.5	28.2	18.2	34.0	24.0	39.7	29.7	45.5	35.5	51.2	41.2	62.7	52.7			27.7	17.7
	09					20.3	9.0	26.0	14.7	31.8	20.5	37.5	26.2	43.3	32.0	49.0	37.7	60.5	49.2	72.1	60.8	31.2	19.9
	10							23.8	11.3	29.6	17.1	35.3	22.8	41.1	28.6	46.8	34.3	58.3	45.8	69.9	57.4	34.6	22.1
	11									27.4	13.6	33.1	19.3	38.9	25.1	44.6	30.8	56.1	42.3	67.7	53.9	38.1	24.6
	12														36.7	21.7	42.4	27.4	53.9	38.9	65.5	50.5	41.5
HP-088S	05	27.8	17.2	37.0	26.4	46.2	35.6	55.4	44.8	64.7	54.1	73.9	63.3	83.1	72.5							28.9	18.3
	06	24.1	11.4	33.3	20.6	42.5	29.8	51.7	39.0	61.0	48.3	70.2	57.5	79.4	66.7	88.6	75.9					34.7	22.0
	07	20.4	5.7	29.6	14.9	38.8	24.1	48.0	33.3	57.3	42.6	66.5	51.8	75.7	61.0	84.9	70.2	103	88.6			40.4	25.7
	08			26.6	9.1	35.2	18.3	44.4	27.5	53.7	36.8	62.9	46.0	72.1	55.2	81.3	64.4	99.7	82.8			46.2	29.3
	09					31.5	12.5	40.7	21.7	50.0	31.0	59.2	40.2	68.4	49.4	77.6	58.6	96.0	77.0	114	95.0	52.0	33.0
	10							37.0	15.9	46.3	25.2	55.5	34.4	64.7	43.6	73.9	52.8	92.3	71.2	110	89.2	57.8	36.7
	11									42.7	19.5	51.9	28.7	61.1	37.9	70.3	47.1	88.7	65.5	107	83.5	63.5	40.3
	12														57.4	32.1	66.6	41.3	85.0	59.7	103	77.7	69.3
HP-100S	05	42.9	28.8	56.6	42.5	70.2	56.1	83.9	69.8	97.5	83.4	111	97.1	125	111							39.4	25.3
	06	37.8	20.9	51.5	34.6	65.1	48.2	78.8	61.9	92.4	75.5	106	89.2	120	103	133	117					47.3	30.4
	07	32.7	13.1	46.4	26.8	60.0	40.4	73.7	54.1	87.3	67.7	101	81.4	115	95.0	128	109	156	136			55.1	35.5
	08			41.4	18.9	55.0	32.5	68.7	46.2	82.3	59.8	96.0	73.5	110	87.1	123	101	151	128			63.0	40.5
	09					49.9	24.6	63.6	38.3	77.2	51.9	90.9	65.6	105	79.2	118	92.9	156	120	168	143	70.9	45.6
	10							58.5	30.4	72.1	44.0	85.8	57.7	99.4	71.3	113	85.0	140	112	163	135	78.8	50.7
	11									67.1	36.1	80.8	49.8	94.4	63.4	108	77.1	135	104	158	127	86.7	55.7
	12														89.3	55.6	103	69.3	130	96.6	153	120	94.5
HP-115S	05	66.5	42.0	88.0	63.5	110	85.0	131	107	153	128	174	150	196	171							65.5	41.0
	06	58.3	28.9	79.8	50.4	101	71.9	123	93.4	114	115	166	136	187	158	209	179					78.6	49.2
	07	50.1	15.8	71.6	37.3	93.1	58.8	115	80.3	136	102	158	123	179	145	207	166	244	209			91.7	57.4
	08			63.4	24.0	84.9	45.5	106	67.0	128	88.5	149	110	171	132	192	153	235	196			105	65.6
	09					76.7	32.5	98.2	54.0	120	75.5	141	97.0	163	119	184	140	227	183	270	226	118	73.8
	10							90.0	41.0	112	62.5	133	84.0	155	106	176	127	219	170	262	213	131	82.0
	11									103	49.5	125	71.0	146	92.5	168	114	211	157	254	200	144	90.2
	12														138	79.5	160	101	203	144	246	187	157
HP-125S	05	86.0	56.5	114	84.2	142	112	169	140	197	167	225	195	252	223							82.0	52.5
	06	75.5	39.5	103	67.2	131	95.0	159	123	186	105	214	178	242	206	270	234					99.0	63.0
	07	65.0	23.5	92.7	51.2	126	79.0	148	107	176	134	204	162	231	190	259	218	314	273			115	73.5
	08			82.2	34.2	110	62.0	138	89.7	165	117	193	145	221	173	249	201	304	256			132	84.0
	09					99.5	46.0	127	73.7	155	101	183	129	210	157	238	185	293	240	349	295	148	94.5
	10							117	56.7	144	84.4	172	112	200	140	228	168	283	223	338	278	165	105
	11									133	68.4	161	96.1	189	124	217	152	272	207	327	262	181	116
	12														179	107	207	135	262	190	317	245	198

Air supply		2.5 bar		3 bar		3.5 bar		4 bar		4.5 bar		5 bar		5.6 bar		6 bar		7 bar		8 bar		Spring		
Model	No. of Spring	0	90	0	90	0	90	0	90	0	90	0	90	0	90	0	90	0	90	0	90	0	90	
		Start	End	Start	End	Start	End	Start	End	Start	End	Start	End	Start	End	Start	End	Start	End	Start	End	Start	End	
HP-145S	05	136	88.5	179	132	223	176	266	219	310	263	353	306	397	350							129	82	
	06	119	62.5	162	106	206	150	249	193	293	237	336	280	380	324	423	367					155	99	
	07	103	37.5	146	81.0	190	125	233	168	277	212	320	255	364	299	407	342	494	429			180	115	
	08			129	55.0	173	98.5	216	142	260	186	303	229	367	273	390	316	477	403			206	132	
	09					157	72.5	200	116	244	160	287	203	331	247	374	290	461	377	548	464	232	148	
	10							183	90.0	227	134	270	177	314	221	357	264	444	351	531	438	258	165	
	11										211	109	254	152	298	196	341	239	428	326	515	413	283	181
	12															281	170	324	213	411	300	498	384	309
HP-160S	05	172	118	229	175	286	231	342	288	399	345	455	401	512	458							166	112	
	06	149	84.7	206	142	262	198	319	255	376	312	432	368	489	425	546	482					199	135	
	07	127	50.7	184	108	240	164	297	221	354	278	410	334	467	391	524	448	637	561			233	157	
	08			161	74.5	217	131	274	188	331	245	387	301	444	358	501	415	614	528			266	180	
	09					195	98.2	252	155	309	212	365	268	422	325	479	382	592	495	706	609	299	202	
	10							230	122	287	179	343	235	400	292	457	349	570	462	684	576	332	224	
	11										264	146	320	202	377	259	434	316	547	429	661	543	365	
	12															355	225	412	282	525	395	639	509	399
HP-180S	05	225	146	301	222	378	299	455	376	531	452	608	529	684	605							237	158	
	06	193	98.8	269	175	346	252	423	329	499	405	576	482	652	558	729	635					284	190	
	07	162	50.8	238	127	315	204	392	281	468	357	545	434	621	510	698	587	851	740			332	221	
	08			206	80.4	283	157	360	234	436	310	513	387	289	463	666	540	819	693			379	253	
	09					251	110	328	187	404	263	481	340	557	416	634	493	787	646	940	799	426	285	
	10							297	139	373	215	450		526	368	603	445	756	598	909	751	474	316	
	11										341	168	418	245	494	321	508	398	724	551	877	704	521	348
	12															463	274	540	351	693	504	843	657	568
HP-200S	05	319	217	425	323	531	429	638	536	744	642	850	748	957	855							315	213	
	06	277	154	383	260	489	366	596	473	702	579	808	685	915	792	1021	898					378	255	
	07	234	90.7	340	197	446	303	553	410	659	516	765	622	872	729	978	835	1191	1048			441	298	
	08			298	134	404	240	511	347	617	453	723	559	830	666	936	772	1149	985			504	340	
	09					361	177	468	284	574	390	680	496	787	603	893	709	1106	922	1319	1135	567	383	
	10							426	221	532	327	638	433	745	540	851	646	1064	859	1277	1072	630	425	
	11										489	264	595	370	702	477	808	583	1021	796	1234	1009	693	468
	12															660	414	766	520	979	733	1191	946	756
HP-210S	04	430	313	547	430	665	547	782	665													274	157	
	05	391	244	508	362	626	479	743	596	860	714	978	831	1095	948							343	196	
	06	352	176	469	293	586	410	704	528	821	645	939	762	1056	880	1173	997					411	253	
	07			430	224	547	342	664	459	782	576	899	694	1017	811	1134	929	1369	1163			480	275	
	08					508	273	625	391	743	508	860	625	977	743	1095	860	1330	1095			549	314	
	09					469	205	586	322	703	439	821	557	938	674	1056	791	1290	1026	1525	1261	617	353	
	10					429	136	547	253	664	371	782	488	899	606	1016	723	1251	958	1486	1192	686	392	
	11										625	302	742	420	860	537	977	654	1212	889	1447	1124	754	431
12										586	234	703	351	821	468	938	586	1173	821	1407	1055	823	471	

Scotch Yoke

▪ Double Acting (Torque: Nm)

Model	Air Supply								
	4.2 bar			5.6 bar			7 bar		
	Start	Run	End	Start	Run	End	Start	Run	End
HP-211D	1,507	753	1,312	2,009	1,005	1,705	2,511	1,255	2,187
HP-212D	3,011	1,506	2,622	4,017	2,006	3,498	5,022	2,509	4,373

▪ Single Acting (Torque: Nm)

Model	4.2 bar						5.6 bar					
	Air Torque			Spring Torque			Air Torque			Spring Torque		
	Start	Run	End	Start	Run	End	Start	Run	End	Start	Run	End
HP-211S	1,114	452	634	678	283	393	1,385	537	724	1,026	446	624
HP-212S	2,226	904	1,266	1,356	565	780	2,769	1,074	1,446	2,045	883	1,243

Rack & Pinion

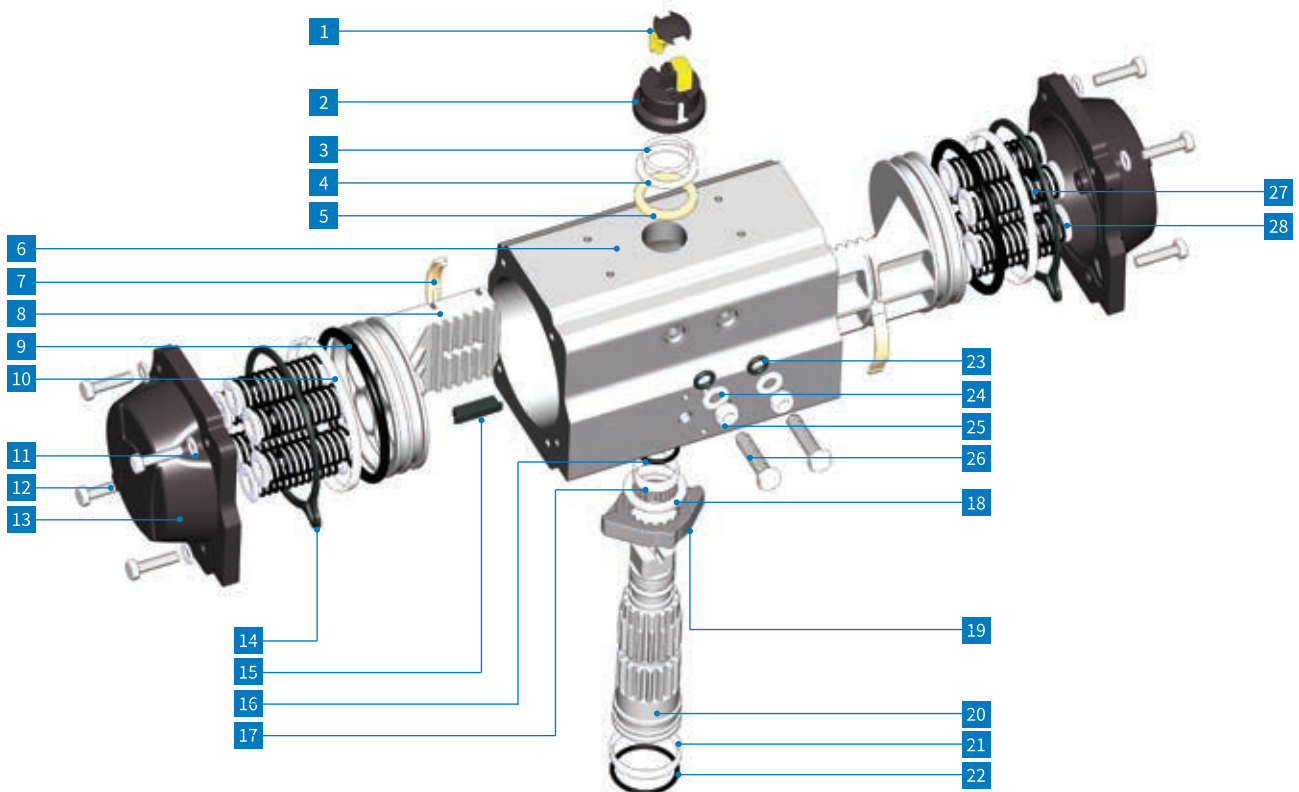

* Recommended spare parts

No.	Description	Material	Corrosion Protection	Optional Material	Q'ty
1	Position indicator	Polypropylene + GF	-	-	2
2	Position indicator holder	Polypropylene + GF	-	-	1
3	Spring clip (pinion)	Stainless steel	Nickel plated (HP-160, HP-200)	-	1
4	Thrust washer (pinion)	Stainless steel	-	-	1
5	Thrust bearing (pinion)	Polyphthalamide	-	-	1
6	Body	Extruded aluminium alloy	Soft or hard anodized	-	1
7	Bearing (piston back)	Polyphthalamide	-	-	2
8	Piston	Die cast aluminium	Soft or hard anodized	-	2
* 9	O-ring (piston)	Nitrile (NBR70)	-	FKM, VMQ	2
* 10	Bearing (piston head)	Polyphthalamide	-	-	2
11	Cover bolt washer	Stainless steel	-	-	8
12	Cover bolt (end cover)	Stainless steel	-	-	2
13	Right and left end cover	Die cast aluminium	Chromated + polyester coated	-	2
* 14	O-ring (end cover)	Nitrile (NBR70)	-	FKM, VMQ	2
* 15	Piston guide	Polyphthalamide	-	-	2
* 16	O-ring (pinion top)	Nitrile (NBR70)	-	FKM, VMQ	1
* 17	Bearing (piston top)	Nylon 46	-	-	1
* 18	Thrust bearing (pinion)	Polyphthalamide	-	-	1
19	Open, close cam (stop arrangement)	Stainless steel	-	-	1
20	Drive shaft	Alloy steel	Nickel plated	-	1
* 21	Bearing (pinion bottom)	Nylon 46	-	-	1
* 22	O-ring (pinion bottom)	Nitrile (NBR70)	-	FKM, VMQ	1
* 23	O-ring (stop screw)	Nitrile (NBR70)	-	FKM, VMQ	1
24	Stop bolt washer	Stainless steel	-	-	2
25	Stop nut	Stainless steel	-	-	2
26	Stop bolt	Stainless steel	-	-	2
27	Spring	High alloy spring steel	Epoxy coated	-	5 - 12
28	Spring holder	Polypropylene + GF	-	-	1

Scotch Yoke

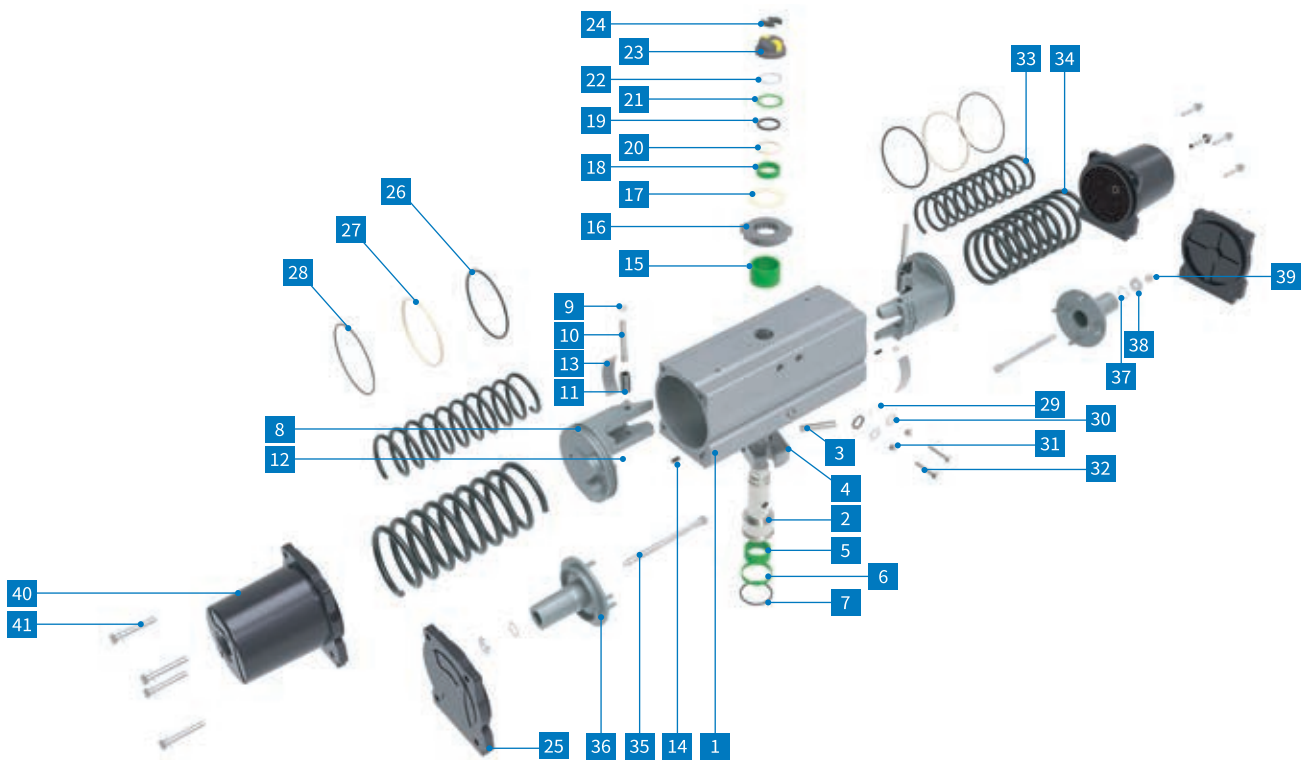

* Recommended spare parts

No.	Description	Material	Q'ty
1	Cylinder body	Aluminum alloy	1
2	Drive shaft	Alloy steel	1
3	Yoke pin	Steel	1
4	Yoke	Steel	1
5	Bottom spacer	Nylon	1
* 6	Stem bottom bearing	Stainless steel	1
* 7	Stem bottom o-ring	NBR	1
8	Piston	Aluminum	2
9	Snap ring	Stainless steel	2
10	Roller pin	Steel	1
11	Shaft	Steel	1
12	Snap ring	Stainless steel	2
13	Piston back bearing	PTFE	3
14	Hole sealant	NBR	2
15	Top spacer	Nylon	1
16	OCT cam	Steel	1
* 17	Stem thrust bearing	Stainless steel	1
* 18	Stem top bearing	Stainless steel	1
* 19	Stem top O-ring	NBR	1
* 20	Teflon washer	PTFE	1
* 21	Stem thrust washer	Stainless steel	1
22	Snap ring	Stainless steel	5
23	Indicator	ABS	1
24	Indicator holder cover	ABS	1
25	Double acting cover	Aluminum	2
* 26	Piston o-ring	NBR	2
* 27	Piston head bearing	PTFE	3
* 28	Cover o-ring	NBR	2

No.	Description	Material	Q'ty
* 29	Stop bolt o-ring	NBR	2
30	Stop bolt washer	Stainless steel	2
31	Stop bolt nut	Stainless steel	2
32	Stop bolt	Stainless steel	2
33	Inner spring	Spring steel	1 - 2
34	Outer spring	Spring steel	1 - 2
35	Spring bolt	Stainless steel	1 - 2
36	Spring retainer	Aluminum	1 - 2
37	Spring o-ring	NBR	1 - 2
38	Spring washer	Steel	1 - 2
39	Spring nut	Stainless steel	1 - 2
40	Spring retainer cover	Aluminum	2
41	Cover bolt	Stainless steel	8

Dimensional Drawing

HP-035D

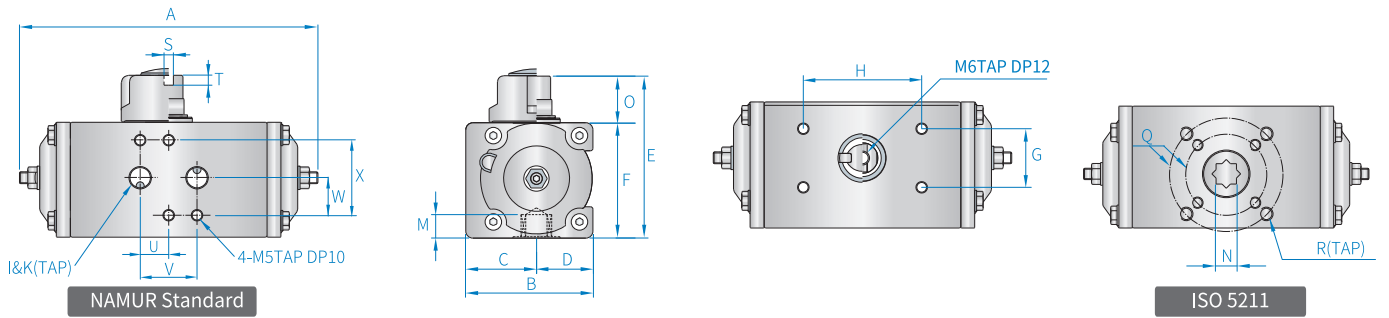

HP-050 to HP-210

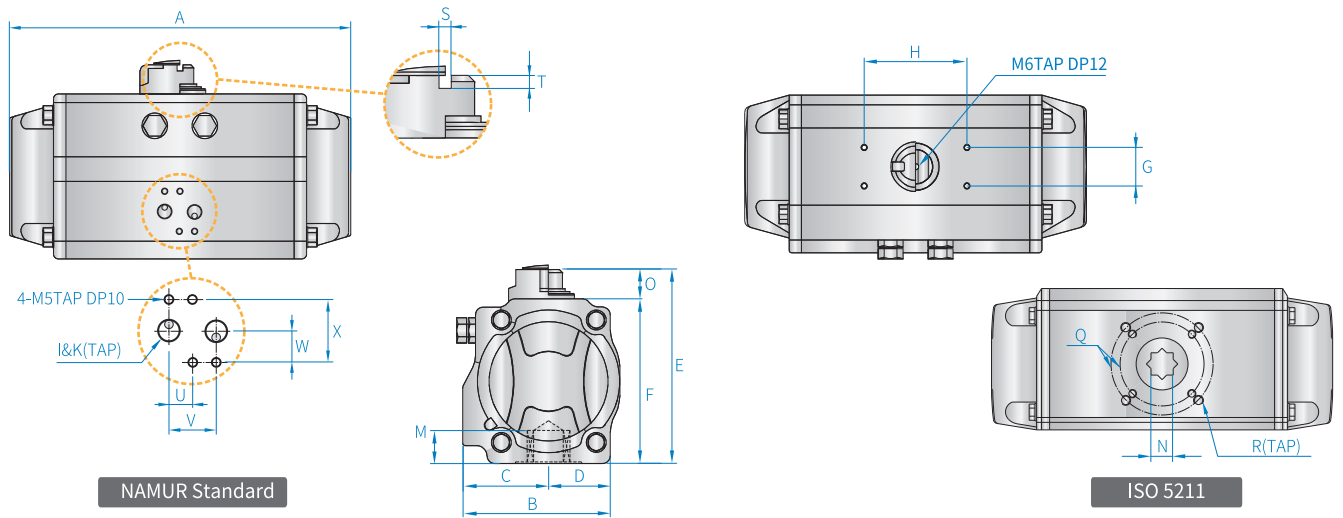

Unit: mm

Model	Flange (ISO 5211)		R																
	Q	M/N (min)	A	B	C	D	E	F	G	H	I	K	O	S	T	U	V	W	X
HP-035D	F03/F05 Ø36/Ø50	M5/M6 10/9	126	54	30	24	69	49	25	50	PF	1/8"	20	4	4	12	24	16	32
HP-050	F03/F05 Ø36/Ø50	M5/M6 14/11	144	72	42	30	93	73	30	80	PF	1/8"	20	4	4	12	24	16	32
HP-063	F05/F07 Ø50/Ø70	M6/M8 18/14	163	85	47	38	107	87	30	80	PF	1/8"	20	4	4	12	24	16	32
HP-066	F05/F07 Ø50/Ø70	M6/M8 18/14	202	85	47	38	107	87	30	80	PF	1/8"	20	4	4	12	24	16	32
HP-075	F05/F07 Ø50/Ø70	M6/M8 22/17	210	96	53.5	42.5	124	104	30	80	PF	1/8"	20	4	4	12	24	16	32
HP-088	F05/F07/F10 Ø50/Ø70/Ø102	M6/M8/M10 22/17	247	108	58.5	49.5	136	116	30	80	PF	1/8"	20	4	4	12	24	16	32
HP-100	F05/F07/F10 Ø50/Ø70/Ø102	M6/M8/M10 22/17	268	123	67	56	148	128	30	80	PF	1/8"	20	4	4	12	24	16	32
HP-115	F07/F10 Ø70/Ø102	M8/M10 32/22	316	141	77	64	166	146	30	80	PF	1/8"	20	4	4	12	24	16	32
HP-125	F07/F10/F12 Ø70/Ø102/Ø125	M8/M10/M12 32/22	347	151	82	69	179	159	30	80	PF	1/4"	20	4	4	12	24	16	32
HP-145	F10/F12 Ø102/Ø125	M10/M12 36/27	414	172	92	80	209	179	30	80	PF	1/4"	30	4	4	12	24	16	32
HP-160	F10/F12 Ø102/Ø125	M10/M12 36/27	467	190	101	89	226	196	30	130	PF	1/4"	30	4	4	12	24	16	32
HP-180	F10/F12 Ø102/Ø125	M10/M12 39/36	497	206	107	99	251	221	30	130	PF	1/4"	30	4	4	12	24	16	32
HP-200	F14 Ø140	M16 39/36	555	227	116	111	277	247	30	130	PF	1/4"	30	4	4	12	24	16	32
HP-210	F14 Ø140	M16 43/36	628	236	120	116	286	256	30	130	PF	1/4"	30	4	4	12	24	16	32

HP-211 / HP-212

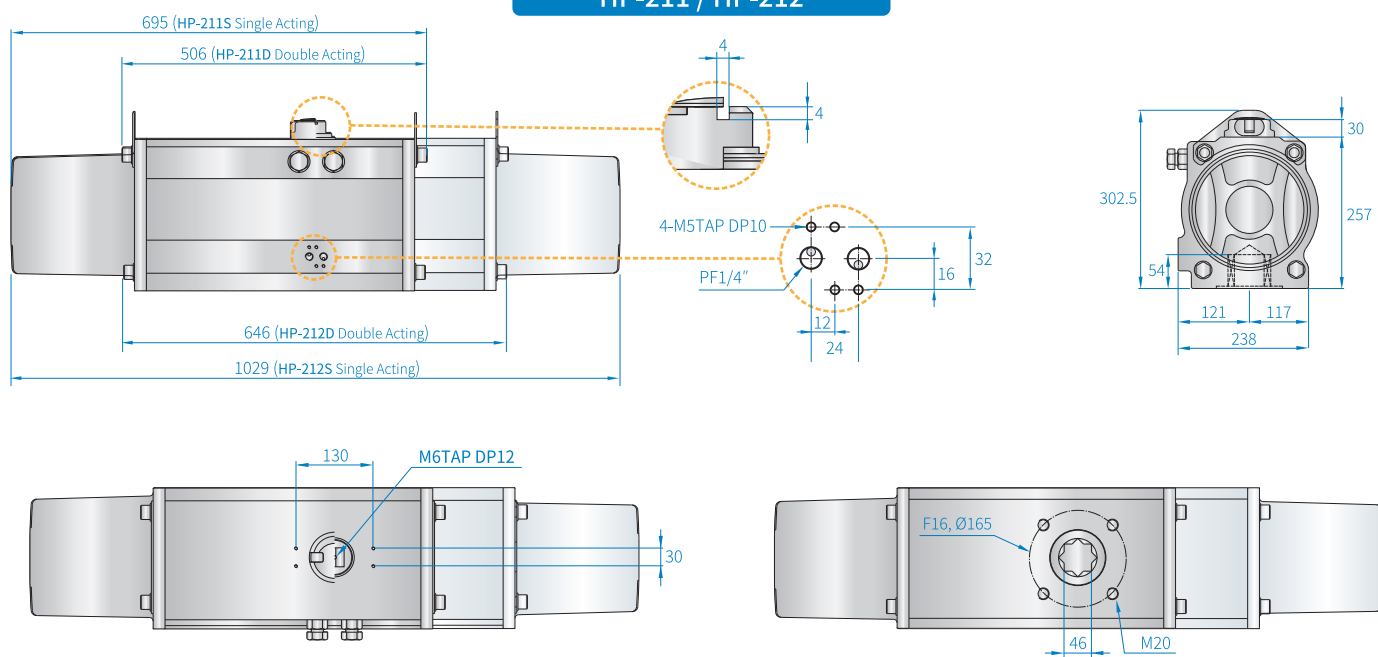

135° turn

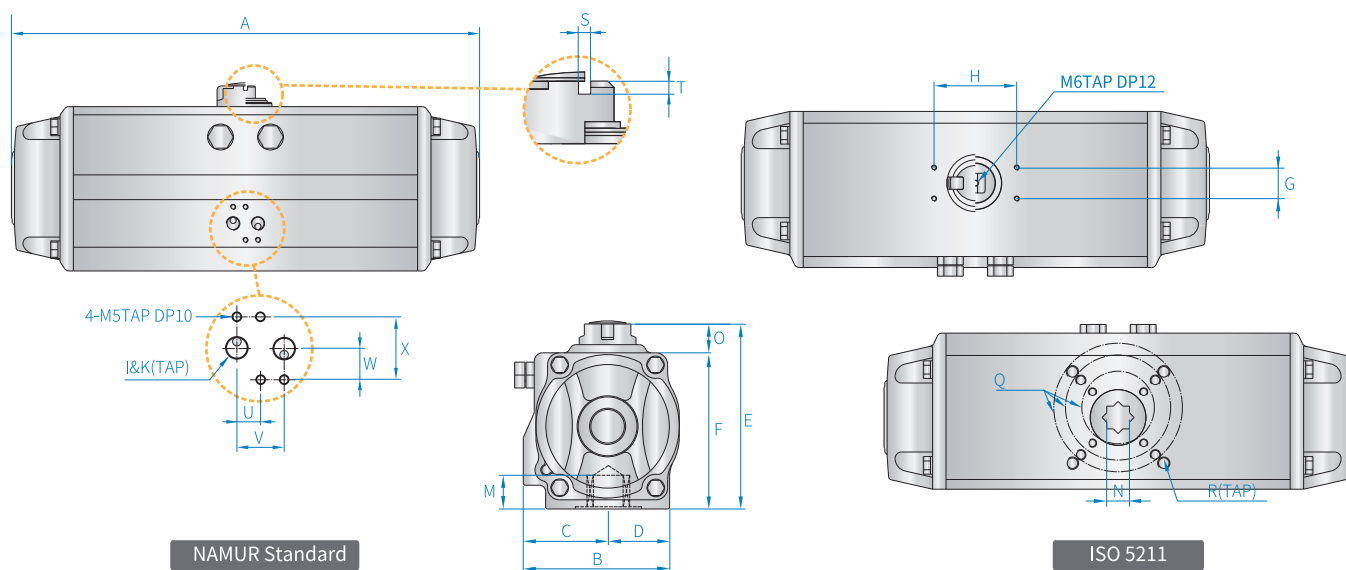

Unit: mm

Model	Flange (ISO 5211)		R																
	Q	M/N (min)	A	B	C	D	E	F	G	H	I	K	O	S	T	U	V	W	X
HP-075D(135°)	F05/F07 Ø50/Ø70	M6/M8 22/17	272	96	53.5	42.5	124	104	30	80	PF	1/8"	20	4	4	12	24	16	32
HP-100D(135°)	F05/F07/F10 Ø50/Ø70/Ø102	M6/M8/M10 22/17	346	123	67	56	148	128	30	80	PF	1/8"	20	4	4	12	24	16	32
HP-125D(135°)	F07/F10/F12 Ø70/Ø102/Ø125	M8/M10/M12 32/22	453	151	82	69	179	159	30	80	PF	1/4"	20	4	4	12	24	16	32
HP-145D(135°)	F10/F12 Ø102/Ø125	M10/M12 36/27	545	172	92	80	209	179	30	80	PF	1/4"	30	4	4	12	24	16	32
HP-180D(135°)	F10/F12 Ø102/Ø125	M10/M12 39/36	704	206	107	99	251	221	30	130	PF	1/4"	30	4	4	12	24	16	32
HP-200D(135°)	F14 Ø140	M16 39/36	727	227	116	111	277	247	30	130	PF	1/4"	30	4	4	12	24	16	32

Air Consumption

Double Acting 90° turn

Unit: liter (L)

Model	Volume	Air Supply									
		2.5 bar	3 bar	3.5 bar	4 bar	4.5 bar	5 bar	5.6 bar	6 bar	7bar	8 bar
HP-035D	0.2	0.7	0.8	0.9	1.0	1.1	1.2	1.3	1.4	1.6	1.8
HP-050D	0.3	1.1	1.2	1.4	1.5	1.7	1.8	2.0	2.1	2.5	2.8
HP-063D	0.5	1.8	2.0	2.3	2.6	2.8	3.1	3.3	3.6	4.1	4.6
HP-066D	0.5	2.1	2.5	2.8	3.1	3.4	3.7	4.0	4.3	4.9	5.5
HP-075D	0.8	2.9	3.3	3.7	4.1	4.5	4.9	5.3	5.7	6.5	7.4
HP-088D	1.3	4.7	5.3	6.0	6.6	7.3	8.0	8.6	9.3	10.6	11.9
HP-100D	1.8	6.4	7.4	8.3	9.2	10.1	11.0	12.0	12.9	14.7	16.5
HP-115D	3.0	10.7	12.3	13.8	15.3	16.9	18.4	19.9	21.5	24.5	27.6
HP-125D	3.8	13.6	15.6	17.5	19.4	21.4	23.3	25.2	27.2	31.0	34.9
HP-145D	6.2	22.2	25.4	28.5	31.7	34.9	38.0	41.2	44.3	50.7	57.0
HP-160D	7.3	26.2	29.9	33.6	37.3	41.0	44.8	48.5	52.2	59.6	67.1
HP-180D	11.2	40.1	45.8	51.5	57.3	63.0	68.7	74.4	80.1	91.5	102.9
HP-200D	15.4	55.2	63.0	70.9	78.7	86.6	94.4	102.3	110.1	125.8	141.5
HP-210D	16.0	57.3	65.5	73.6	81.8	89.9	98.1	106.3	114.4	130.7	147.1
HP-211D	13.7	49.1	56.1	63.0	70.0	77.0	84.0	91.0	98.0	111.9	125.9
HP-212D	20.3	72.7	83.1	93.4	103.8	114.1	124.5	134.8	145.2	165.9	186.6

Double Acting 135° turn

Unit: liter (L)

Model	Volume	Air Supply									
		2.5 bar	3 bar	3.5 bar	4 bar	4.5 bar	5 bar	5.6 bar	6 bar	7bar	8 bar
HP-075D	1.2	4.2	4.8	5.3	5.9	6.5	7.1	7.7	8.3	9.5	10.7
HP-100D	2.6	9.3	10.7	12.0	13.3	14.6	16.0	17.3	18.6	21.3	23.9
HP-125D	5.5	19.9	22.7	25.5	28.3	31.2	34.0	36.8	39.6	45.3	50.9
HP-145D	9.2	32.9	37.6	42.3	47.0	51.7	56.4	61.1	65.8	75.2	84.5
HP-180D	16.4	58.6	67.0	75.3	83.7	92.0	100.3	108.7	117.0	133.7	150.4
HP-200D	22.9	82.2	93.9	105.6	117.3	129.0	140.7	152.4	164.1	187.5	210.9

Single Acting 90° turn

Unit: liter (L)

Model	Volume	Air Supply									
		2.5 bar	3 bar	3.5 bar	4 bar	4.5 bar	5 bar	5.6 bar	6 bar	7bar	8 bar
HP-050D	0.1	0.4	0.4	0.5	0.5	0.6	0.6	0.7	0.7	0.8	0.9
HP-063D	0.2	0.7	0.8	0.9	1.0	1.1	1.2	1.3	1.4	1.6	1.8
HP-066D	0.2	0.9	1.0	1.2	1.3	1.4	1.5	1.7	1.8	2.0	2.3
HP-075D	0.3	1.1	1.2	1.4	1.5	1.7	1.8	2.0	2.1	2.5	2.8
HP-088D	0.5	1.8	2.0	2.3	2.6	2.8	3.1	3.3	3.6	4.1	4.6
HP-100D	0.7	2.5	2.9	3.2	3.6	3.9	4.3	4.6	5.0	5.7	6.4
HP-115D	1.2	4.3	4.9	5.5	6.1	6.7	7.3	8.0	8.6	9.8	11.0
HP-125D	1.5	5.4	6.1	6.9	7.7	8.4	9.1	10.0	10.7	12.3	13.8
HP-145D	2.4	8.6	9.8	11.0	12.3	13.5	14.6	15.9	17.2	19.6	22.1
HP-160D	3.1	11.1	12.7	14.3	15.8	17.4	18.9	20.6	22.2	25.3	28.5
HP-180D	4.3	15.4	17.6	19.8	22.0	24.2	26.2	28.6	30.8	35.1	39.5
HP-200D	5.9	21.1	24.1	27.2	30.2	33.2	36.0	39.2	42.2	48.2	54.2
HP-210D	7.8	27.9	31.9	35.9	39.9	43.8	47.6	51.8	55.8	63.7	71.7
HP-211D	5.1	18.3	20.9	23.5	26.1	28.7	31.1	33.9	36.5	41.7	46.9
HP-212D	9.6	34.4	39.9	44.2	49.1	54.0	58.5	63.8	68.7	78.4	88.2

Weight

Rack & Pinion

Model	90° turn	135° turn	Spring 1 each
HP-035	0.5		N/A
HP-050	1.2		0.009
HP-063	1.7		0.017
HP-066	2.4		0.021
HP-075	3.1	4.1	0.033
HP-088	4.3		0.056
HP-100	6.1	8.8	0.078
HP-115	9.0		0.121
HP-125	11.3	15.3	0.165
HP-145	14.1	22.9	0.202
HP-160	22.0		0.359
HP-180	26.5	36.7	0.521
HP-200	38.4	49.7	0.752
HP-210	46.0		0.882

Scotch Yoke

Model	90° turn
HP-211D	46.1
HP-211S (4.2 bar)	59.8
HP-211S (5.6 bar)	64.0
HP-212D	71.1
HP-212S (4.2 bar)	85.9
HP-211S (5.6 bar)	95.3

Ordering Code

Example:

HP-¹075²S³(12)⁴01⁴00⁶0⁷0⁸0

1	Model
035	HP-035
050	HP-050
063	HP-063
066	HP-066
075	HP-075
088	HP-088
100	HP-100
115	HP-115
125	HP-125
145	HP-145
160	HP-160
180	HP-180
200	HP-200
210	HP-210
211	HP-211
212	HP-212

2	Acting Type
D	Double Acting
S	Single Acting

3	No. of Springs
(05)	05
(06)	06
(07)	07
(08)	08
(09)	09
(10)	10
(11)	11
(12)	12

4	Cover Color
01	● Black (RAL 9005)
06	● Red (RAL 3001)
16	● Blue (RAL 5005)
11	● Yellow (RAL 1033)
SP	● Other colors
NC	○ Nano Coating

5	Body
00	Soft anodized
27	Hard anodized
SP	● Other colors
NC	○ Nano Coating

6	Travel Angle
0	90°
1	135°

7	Side Stopper
0	N/A
S	Side

8	Temperature
0	Standard: -20 to +80 °C
L	Low temperature: -40 to +80 °C
H	High temperature: -20 to +150 °C

Limit Switch Box APL Series

Description

Providing accurate and reliable valve position monitoring, APL Series limit switch boxes are designed for quarter-turn valve applications, used in many many industries:

Wide range of application

With reliable and stable operation, the HQ Series is used in many industries:

- Oil & gas
- Power plant
- Chemical & petrochemical
- Water
- Marine
- General industries

Quick and easy installation

APL Series provides quick and easy installation with pre-wired switches and pre-set cams. It has pring loaded splined cams which can be adjusted without requiring any tools. Once the initial setting ahs been done, there is no need for further adjustment. Also, a full line of NAMUR standard mounting brackets are available for all APL Series.



Wide ragne of Product Selection

APL Series has a wide range of products with many types of switches, sensors, and other options to cover various customer needs: cost-effective, corrosive & hostile environments, IP ratings (IP67, IP68, NEMA 4, 4X, 6), explosion proof enclosure, low/high operating temperature, 3-way valve applications, stainless steel 316L body & cover, current position signaling, 120° & 135° valve applications and many more.

Models

APL-2
weatherproof



APL-3
weatherproof



APL-9
weatherproof



APL-4
Ex db IIB T6



APL-5
Ex db IIC T6



APL-7
Ex db IIC T5



APL-8 Series
Ex db IIC T6



Limit Switch Box APL-2 for General Purpose

Features

- Aluminum die-cast, compact size, and light weight
- High corrosion resistance due to double chromate treatment and polyester powder coating.
- Double sealed indicator that prevents water ingress in case of a dome failure.
- With spring loaded cams, limit positions can be easily set without tools.



Certificates and approvals

- EAC
- SIL 2 (SC 3)
- ABS type approval
- RMRS type approval
- RINA type approval



Specification

Standard Specification

Enclosure	Weatherproof enclosure IP67, type 4X High grade aluminium alloy, chromate treated twice & polyester powder coated
Travel angle	0 - 90 °
Ambient temperature	-20 to +80 °C
Cable entry	2 x PF1/2", 2 x NPT1/2", 2 x M20
Switches	2 x mechanical switches or proximity sensors
Terminal points	8 points
Weight	0.5 kg (without bracket)
Indicator	2-way yellow (open) / red (close) 2-way green (open) / red (close)
Bracket	Stainless steel 304, MBP-100 (30 x 80, H:20)
Coating (color)	● Black (RAL 9005), ● Red (RAL 3001), ● Blue (RAL 5005), ● Yellow (RAL 1033), ● Grey (RAL 7046), ● Green (RAL 6034)

Optional Specification

Enclosure rating	WTA Watertight enclosure actuator (IP68 10 m 72 hr)
Travel angle	0 - 120°, 135°
Indicator	L-port 3-way, yellow (open) / red (close) L-port 3-way, green (open) / red (close) T-port 3-way, yellow (open) / red (close) T-port 3-way, green (open) / red (close)
Bracket	Stainless steel 304 or 316, MBP-050 (25 x 50, H20), MBP-200 (30 x 80, H30), MBP-300 (30 x 130, H:30), MBP-400 (30 x 130, H:50)
Coating (color)	● Other colors, ○ Nano coating (for corrosive environment)

Limit Switch Box APL-3 for General Purpose

Features

- Aluminum die-cast, compact size, and light weight
- High corrosion resistance due to double chromate treatment and polyester powder coating.
- Double sealed dome indicator that prevents water ingress in case of a dome failure.
- With spring loaded cams, limit positions can be easily set without tools.
- Upto 4 mechanical switches or proximity sensors



Certificates and approvals

- EAC
- SIL 2 (SC 3)
- S mark
- ABS type approval
- RMRS type approval
- RINA type approval



Specification

Standard Specification

Enclosure	Weatherproof enclosure IP67, type 4X High grade aluminium alloy, chromate treated twice & polyester powder coated
Travel angle	0 - 90°
Ambient temperature	-20 to +80 °C
Cable entry	2 x PF1/2", 2 x NPT1/2", 2 x M20
Switches	2 x mechanical switches or proximity sensors
Terminal points	8 points
Weight	0.5 kg (without bracket)
Indicator	2-way yellow (open) / red (close) 2-way green (open) / red (close)
Bracket	Stainless steel 304, MBP-100 (30 x 80, H:20)
Coating (color)	● Black (RAL 9005), ● Red (RAL 3001), ● Blue (RAL 5005), ● Yellow (RAL 1033), ● Grey (RAL 7046), ● Green (RAL 6034)

Optional Specification

Enclosure rating	WTA Watertight enclosure actuator (IP68 10 m 72 hr)
Travel angle	0 - 120°, 135°
Ambient temperature	LT low temperature: -40 to +60 °C, HT high temperature: -20 to +150 °C (APL-6 series)
Switches	4 x mechanical switches or proximity sensors
Terminal points	10, 12, 14 points
Control	PIU Potentiometer (1 kΩ, 10 kΩ) CPT Current Position Transmitter (output: 4 - 20 mA dc)
Indicator	L-port 3-way yellow (open) / red (close), L-port 3-way green (open) / red (close) T-port 3-way yellow (open) / red (close), T-port 3-way green (open) / red (close)
Bracket	Stainless steel 304 or 316, MBP-050 (25 x 50, H20), MBP-200 (30 x 80, H30), MBP-300 (30 x 130, H:30), MBP-400 (30 x 130, H:50) Carbon steel (C) or stainless steel 304 (S), MBP-O-1(30 x 80, H20), MBP-O-2 (30 x 80, H30), MBP-O-3 (30 x 130, H:30), MBP-O-4 (30 x 130, H:50)
Coating (color)	● Other colors, ○ Nano coating (for corrosive environment)

Limit Switch Box APL-4 for Explosion proof

Features

- Aluminum die-cast, and robust
- Up to 20 terminal points
- Double sealed dome indicator that prevents water ingress in case of a dome failure.
- With spring loaded cams, limit positions can be easily set without tools.
- Upto 4 mechanical switches or proximity sensors



Certificates and approvals

- IECEx (Ex db IIB T6)
- ATEX (II 2G Ex db IIB T6)
- CSA (Class I, Division 1, Groups C & D T6)
- EAC (1 Ex d IIB T6 Gb)
- KCs (Ex d IIB T6 IP67)
- CCC (Ex db IIB T6)
- SIL 2 (SC 3)
- RMRS type approval
- RINA type approval



Specification

Standard Specification

Enclosure	Flameproof enclosure Ex db IIB T6, weatherproof enclosure IP67, type 4X, 6 High grade aluminium alloy, chromate treated twice & polyester powder coated
Travel angle	0 - 90 °
Ambient temperature	-20 to +60 °C
Cable entry	2 x NPT1/2", NPT1/2", M20, M25
Switches	2 x mechanical switches or proximity sensors
Terminal points	8 points
Weight	3.1 kg (without bracket)
Indicator	2-way yellow (open) / red (close), 2-way green (open) / red (close)
Bracket	Carbon steel (C), MBP-O-1C(30 x 80, H20)
Coating (color)	● Black (RAL 9005)

Optional Specification

Enclosure rating	WTA Watertight enclosure actuator (IP68 10 m 72 hr)
Ambient temperature	LT low temperature: -40 to +60 °C (except proximity sensors)
Switches	4 x mechanical switches or proximity sensors
Terminal points	10, 12, 14, 20 points
Control	PIU Potentiometer (1 kΩ, 10 kΩ) CPT Current Position Transmitter (output: 4 - 20 mA dc)
Indicator	L-port 3-way yellow (open) / red (close), L-port 3-way green (open) / red (close) T-port 3-way yellow (open) / red (close), T-port 3-way green (open) / red (close)
Bracket	Carbon steel (C) or stainless steel 304 (S), MBP-O-1S(30 x 80, H20), MBP-O-2C/S (30 x 80, H30), MBP-O-3C/S (30 x 130, H:30), MBP-O-4C/S (30 x 130, H:50)
Coating (color)	Other colors, ○ Nano coating (for corrosive environment)

Limit Switch Box APL-5 for Explosion proof

Features

- Aluminum die casting that is lightweight and robust
- High corrosion resistance due to double chromate treatment and polyester powder coating.
- With spring loaded cams, limit positions can be easily set without tools.
- High visibility dome indicator with a double sealed structure prevents water ingress in case of a dome failure
- Stainless steel 316 & flag type indicator options

Certificates and approvals

- IECEx (Ex db IIC T6, Ex ia IIC T6, Ex tb IIIC T85°C, Ex ia IIIC T85°C)
- ATEX (Ex db IIC T6, Ex ia IIC T6, Ex tb IIIC T85°C, Ex ia IIIC T85°C)
- KCs (Ex d IIC T6 IP67, Ex tD A21 IP67 T85°C)
- CCC (Ex db IIC T6, Ex ia IIC T6, Ex tb IIIC T85°C)
- INMETRO (Ex db IIC T6, Ex ia IIC T6, Ex tb IIIC T85 °C)
- CSA (Class I, Division 1, Groups B, C & D T6; Class II, Division 1, Groups E, F & G; Class III)
- EAC (1 Ex d IIC T6)
- SIL 2 (SC 3)
- ABS type approval
- RMRS type approval
- RINA type approval

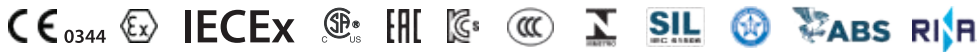

Specification

Standard Specification

Enclosure	Flameproof enclosure Ex db IIC T6, dust ignition proof Ex tb IIIC T85°C, Intrinsic safety Ex ia IIC T6, weatherproof enclosure IP67, type 4X High grade aluminium alloy, chromate treated twice & polyester powder coated		
Travel angle	0 - 90°		
Ambient temperature	-20 to +60 °C		
Cable entry	2 x NPT3/4", NPT1/2", M20	Weight	1.2 kg
Switches	2 x mechanical switches or proximity sensors	Bracket	Stainless steel 304, MBP-100 (30 x 80, H:20)
Terminal points	8 points	Coating (color)	● Black (RAL 9005)
Indicator	2-way yellow (open) / red (close). 2-way green (open) / red (close)		

Optional Specification

Material	S Stainless steel 316		
Enclosure rating	WTA Watertight enclosure actuator (IP68 10 m 72 hr)		
Travel angle	0 - 120°, 135°		
Ambient temperature	LT low temperature: -40 to +60 °C (APL-51X), -25 to +60 °C (APL-52X), -40 to +60 °C (APL-53X), -50 to +60 °C (APL-5HX)		
Switches	4 x mechanical switches or proximity sensors		
Terminal points	10, 12 points		
Control	PIU Potentiometer (1 kΩ, 10 kΩ), CPT Current Position Transmitter (output: 4 - 20 mA dc)		
Indicator	L-port 3-way yellow (open) / red (close), L-port 3-way green (open) / red (close)		
	T-port 3-way yellow (open) / red (close), T-port 3-way green (open) / red (close)		
	Flag Flag type indicator (stainless steel 316 option)		
Bracket	Stainless steel 304 or 316, MBP-050 (25 x 50, H20), MBP-200 (30 x 80, H30), MBP-300 (30 x 130, H:30), MBP-400 (30 x 130, H:50)		
Weight	Stainless steel 316: 3.1 kg (without bracket), stainless steel 316 & flag type indicator: 3.4 kg (without bracket)		
Coating (color)	Other colors, ○ Nano coating (for corrosive environment)		

Limit Switch Box APL-7 for Explosion proof

Features

- Aluminum die casting that is lightweight and robust
- High corrosion resistance due to double chromate treatment and polyester powder coating.
- With spring loaded cams, limit positions can be easily set without tools.
- High visibility dome indicator with a double sealed structure prevents water ingress in case of a dome failure
- Solenoid valve integrated with 3 cable entries

Certificates and approvals

- IECEx (Ex db IIC T5)
- ATEX (Ex db IIC T5)
- KCs (Ex d IIC T6 IP68)
- CCC (Ex db IIC T5)
- SIL 2 (SC 3)
- ABS type approval
- RMRS type approval



Specification

Standard Specification

Enclosure	Flameproof enclosure Ex db IIC T5, weatherproof enclosure IP67 High grade aluminium alloy, chromate treated twice & polyester powder coated
Travel angle	0 - 90 °
Solenoid valve voltage	110/220 V ac 1ph, 50/60 Hz, ±10%, 24 V dc
Solenoid valve port	3-way: NPT1/8, NPT1/4, G1/4, 5-way: NPT1/4, NPT3/8, G1/8, G1/4
Ambient temperature	-20 to +60 °C
Cable entry	3 x NPT3/4", 3 x M20
Switches	2 x mechanical switches or proximity sensors
Terminal points	8 points
Weight	2.1 kg (without bracket)
Indicator	2-way yellow (open) / red (close), 2-way green (open) / red (close)
Bracket	Stainless steel 304, MBP-100 (30 x 80, H:20)
Coating (color)	● Black (RAL 9005)

Optional Specification

Enclosure rating	WTA Watertight enclosure actuator (IP68 10 m 72 hr)
Travel angle	0 - 120°, 135°
Switches	4 x mechanical switches or proximity sensors
Terminal points	10 points
Control	PIU Potentiometer (1 kΩ, 10 kΩ) CPT Current Position Transmitter (output: 4 - 20 mA dc)
Indicator	L-port 3-way yellow (open) / red (close), L-port 3-way green (open) / red (close) T-port 3-way yellow (open) / red (close), T-port 3-way green (open) / red (close)
Bracket	Stainless steel 304 or 316, MBP-050 (25 x 50, H20), MBP-200 (30 x 80, H30), MBP-300 (30 x 130, H:30), MBP-400 (30 x 130, H:50)
Coating (color)	● Other colors, ○ Nano coating (for corrosive environment)

Limit Switch Box APL-8 for Explosion proof

Features

- Aluminum die casting that is lightweight and robust
- High corrosion resistance due to double chromate treatment and polyester powder coating.
- With spring loaded cams, limit positions can be easily set without tools.
- High visibility dome indicator with a double sealed structure prevents water ingress in case of a dome failure
- Stainless steel 316 & flag type indicator options
- 4 cable entries

Certificates and approvals

- IECEx (Ex db IIC T6, Ex ia IIC T6)
- ATEX (Ex db IIC T6, Ex ia IIC T6)
- KCs (Ex d IIC T6)
- CCC (Ex db IIC T6)
- SIL 2 (SC 3)
- ABS type approval
- RMRS type approval



Specification

Standard Specification

Enclosure	Flameproof enclosure Ex db IIC T6, Intrinsic safety Ex ia IIC T6, weatherproof enclosure IP67		
	High grade aluminium alloy, chromate treated twice & polyester powder coated		
Travel angle	0 - 90°		
Ambient temperature	-20 to +60 °C		
Cable entry	4 x NPT3/4", M20	Weight	1.3 kg
Switches	2 x mechanical switches or proximity sensors	Bracket	Stainless steel 304, MBP-100 (30 x 80, H:20)
Terminal points	8 points	Coating (color)	● Black (RAL 9005)
Indicator	2-way yellow (open) / red (close). 2-way green (open) / red (close)		

Optional Specification

Material	S Stainless steel 316		
Enclosure rating	WTA Watertight enclosure actuator (IP68 10 m 72 hr)		
Travel angle	0 - 120°, 135°		
Switches	4 x mechanical switches or proximity sensors		
Terminal points	10 points		
Control	PIU Potentiometer (1 kΩ, 10 kΩ) CPT Current Position Transmitter (output: 4 - 20 mA dc)		
Indicator	L-port 3-way yellow (open) / red (close), L-port 3-way green (open) / red (close) T-port 3-way yellow (open) / red (close), T-port 3-way green (open) / red (close) Flag Flag type indicator (stainless steel 316 option)		
Bracket	Stainless steel 304 or 316, MBP-050 (25 x 50, H20), MBP-200 (30 x 80, H30), MBP-300 (30 x 130, H:30), MBP-400 (30 x 130, H:50)		
Weight	Stainless steel 316: 3.1 kg (without bracket) Stainless steel 316 & flag type indicator: 3.4 kg (without bracket)		
Coating (color)	Other colors, ○ Nano coating (for corrosive environment)		

Limit Switch Box APL-9 for General Purpose

Features

- Press formed stainless steel 304 material that is lightweight, robust and has high corrosion resistance
- With spring loaded cams, limit positions can be easily set without tools
- High visibility dome indicator with a double sealed structure prevents water ingress in case of a dome failure
- Stainless steel 316L option
- Permanent laser marking nameplate
- Flag type indicator option

Certificates and approvals

- ABS type approval
- RMRS type approval
- USCG test approval



Specification



Standard Specification





Enclosure	Weatherproof enclosure IP67 Stainless steel 304
Travel angle	0 - 90 °
Ambient temperature	-20 to +80 °C
Cable entry	2 x M20, 2 x NPT1/2"
Switches	2 x mechanical switches or proximity sensors
Terminal points	8 points
Weight	0.7 kg
Indicator	2-way yellow (open) / red (close) 2-way green (open) / red (close)
Bracket	S type (30 x 80, H:20. 30)

Optional Specification

Material	Stainless steel 316L
Cable entries	Stainless steel 316L : 2 x M20, 2 x M25, 2 x NPT1/2"
Switches	4 x mechanical switches or proximity sensors
Terminal points	10, 12 points
Control	PIU Potentiometer (1 kΩ, 10 kΩ)
Indicator	Flag Flag type indicator
Bracket	O type (30 x 130, H:30, 50)
Weight	Flag type indicator: 0.9 kg
Coating (color)	○ Nano coating (for corrosive environment)

Specification Overview

		APL-2	APL-3	APL-4
Model				
Use		General purpose	General purpose	Explosion proof
Enclosure	Material	Aluminium	Aluminium	Aluminium
	IP rating	Standard: IP67 Option: IP68	Standard: IP67 Option: IP68	Standard: IP67 Option: IP68
	NEMA rating	NEMA 4, 4X	NEMA 4, 4X	NEMA 4X, 6
Explosion proof	IECEX, ATEX	-	-	Ex db IIB T6
	CSA	-	-	Cl. 1, Div. 1, Gr. C,D T6
	EAC	-	-	1 Ex d IIB T6
	KCs	-	-	Ex d IIB T6
	CCC	-	-	Ex db IIB T6 Gb
Other approvals		EAC, SIL, ABS, RMRS, RINA	S mark, EAC, SIL, ABS, RMRS, RINA	SIL, ABS, RMRS, RINA
Travel angle		0-90°	0-90°	0-90°
Ambient temperature		-20 to +80°C	Standard: -20 to +80°C Option (low): -40 to +80°C Option (high): -20 to +150°C	Standard: -20 to +60°C Option (low, CSA): -40 to +60°C (APL-41X)
Cable entries		2 x NPT1/2", PF1/2", M20	3 x NPT3/4", M20	3 x NPT3/4", M20
No. of switches & sensors		2	Standard: 2 Option: 4	Standard: 2 Option: 4
Terminal strips		8 points	Standard: 8 points Option: 10, 12, 14 points	Standard: 8 points Option: 10, 12, 14 points
Shaft		Standard: stainless steel 304 Option: stainless steel 316	Standard: stainless steel 304 Option: stainless steel 316	Standard: stainless steel 304 Option: stainless steel 316
Control option	Potentiometer (PIU)	-	1 kΩ (standard), 10 kΩ	1 kΩ (standard), 10 kΩ
	Current Position Transmitter (CPT)	-	4-20 mA dc 12.5-37.0 V dc (24 V typical)	4-20 mA dc 12.5-37.0 V dc (24 V typical)
Dome indicator		Standard: 2-way Option: No indicator, 3-way (L-port, T-port)	Standard: 2-way Option: No indicator, 3-way (L-port, T-port)	Standard: 2-way Option: No indicator, 3-way (L-port, T-port)
Bracket		Please see page 2	Please see page 3	Please see page 4
Weight (without bracket)		0.5 kg	1.0 kg	3.1 kg
Coating		<ul style="list-style-type: none"> <li style="margin-right: 10px;">● Black <li style="margin-right: 10px;">● Grey <li style="margin-right: 10px;">● Red <li style="margin-right: 10px;">● Emerald green <li style="margin-right: 10px;">● Blue <li style="margin-right: 10px;">● Other colors <li style="margin-right: 10px;">● Yellow <li style="margin-right: 10px;">○ Nano coating 	<ul style="list-style-type: none"> <li style="margin-right: 10px;">● Black <li style="margin-right: 10px;">● Red <li style="margin-right: 10px;">● Yellow <li style="margin-right: 10px;">● Emerald green <li style="margin-right: 10px;">● Other colors <li style="margin-right: 10px;">○ Nano coating 	<ul style="list-style-type: none"> <li style="margin-right: 10px;">● Black <li style="margin-right: 10px;">● Other colors <li style="margin-right: 10px;">○ Nano coating

APL-5	APL-7	APL-8	APL-9
			
Explosion proof	Explosion proof	Explosion proof	General purpose
Standard: aluminium Option: stainless steel 316	Aluminium	Standard: aluminium Option: stainless steel 316	Standard: stainless steel 304 Option: stainless steel 316L
Standard: IP67 Option: IP68	Standard: IP67 Option: IP68	Standard: IP67 Option: IP68	Standard: IP67
NEMA 4X, 6	-	-	-
Ex db IIC T6 Ex ia IIC T6 Ex tb IIIC T85°C Ex ia IIIC T85°C	Ex db IIC T5	Ex db IIC T6 Ex tb IIIC T85°C Ex ia IIC T6	-
Cl. 1, Div. 1, Gr. B,C,D T6; Cl. 2, Div. 1, Gr. E,F,G; Cl.3	-	-	-
1 Ex d IIC T6	-	-	-
Ex d IIC T6 Ex tD A21	Ex d IIC T6	Ex d IIC T6	-
Ex db IIC T6 Ex ia IIC T6 Ex tb IIIC T85°C	Ex d IIC T5 Gb	Ex d IIC T6 Gb	-
SIL, ABS, RMRS, RINA	SIL, ABS, RMRS	SIL, ABS, RMRS	ABS, RMRS, USCG test
Standard: 0-90° Option: 0-120°, 0-135°	Standard: 0-90° Option: 0-120°, 0-135°	Standard: 0-90° Option: 0-120°, 0-135°	0-90°
Standard: -20 to +60°C Option (low, CSA): -40 to +60°C (APL-51X) -25 to +60°C (APL-52X) -40 to +60°C (APL-53X) -50 to +60°C (APL-5HX)	-20 to +60°C	-20 to +60°C	Standard: -20 to +80°C
Standard: 2 x NPT3/4", NPT1/2", M20 Stainless steel 316 option: 2 x NPT3/4", NPT1/2", M20	3 x NPT3/4", M20	Standard: 4 x NPT3/4", M20 Stainless steel 316 option: 2 x NPT3/4", M20	Stainless steel 304 (std): 2 x NPT1/2", M20 Stainless steel 316L option 2 x NPT1/2", M20, M25
Standard: 2 Option: 4	Standard: 2 Option: 4	Standard: 2 Option: 4	2
Standard: 8 points Option: 10, 12, 14 points	Standard: 8 points Option: 10, 12, 14 points	Standard: 8 points Option: 10, 12, 14 points	Standard: 8 points Option: 10, 12 points
Standard: stainless steel 304 Option: stainless steel 316	Standard: stainless steel 304 Option: stainless steel 316	Standard: stainless steel 304 Option: stainless steel 316	Standard: stainless steel 304 Option: stainless steel 316
1 kΩ (standard), 10 kΩ	1 kΩ (standard), 10 kΩ	1 kΩ (standard), 10 kΩ	1 kΩ (standard), 10 kΩ
4-20 mA dc 12.5-37.0 V dc (24 V typical)	4-20 mA dc 12.5-37.0 V dc (24 V typical)	4-20 mA dc 12.5-37.0 V dc (24 V typical)	-
Standard: 2-way Option: No indicator, 3-way (L-port, T-port), flag type (stainless steel 316)	Standard: 2-way Option: No indicator, 3-way (L-port, T-port)	Standard: 2-way Option: No indicator, 3-way (L-port, T-port), flag type (stainless steel 316)	Standard: 2-way Option: No indicator, flag type
Please see page 5	Please see page 6	Please see page 7	Please see page 8
Standard: 1.5 kg SS316 option: 3.1 kg SS316 & flag type: 3.4 kg	2.1 kg	Standard: 1.3 kg SS316 option: 4.2 kg SS316 & flag type: 4.5 kg	Standard: 0.7 kg Flag type: 0.9 kg
● Black ● Other colors ○ Nano coating	● Black ● Other colors ○ Nano coating	● Black ● Other colors ○ Nano coating	○ Nano coating

Dimensional Drawing

APL-2

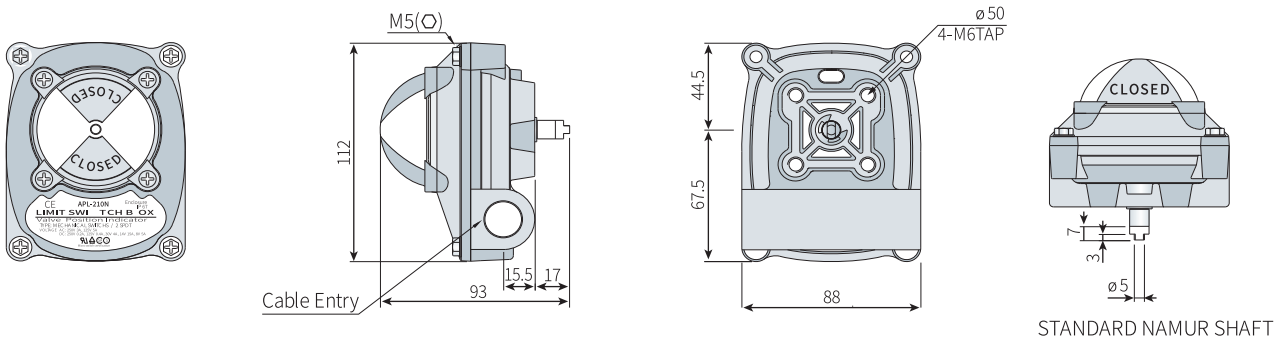

APL-3

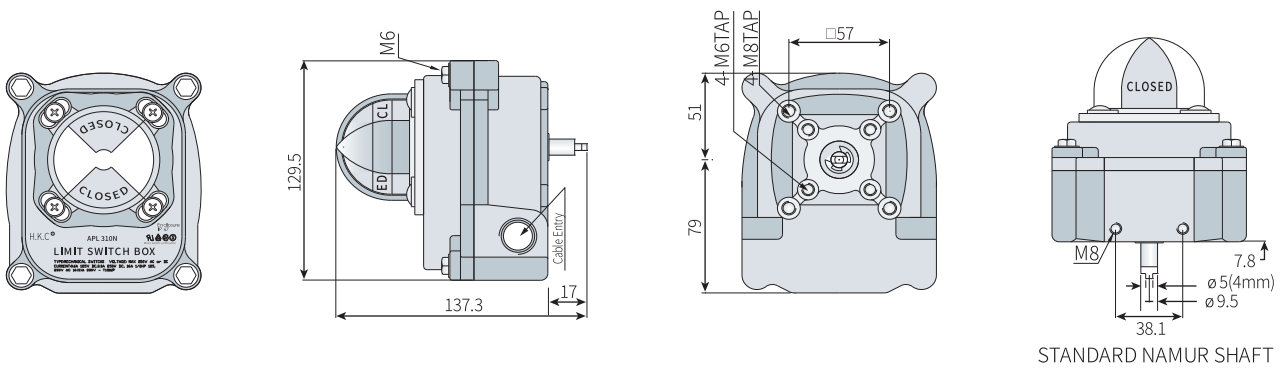

APL-4

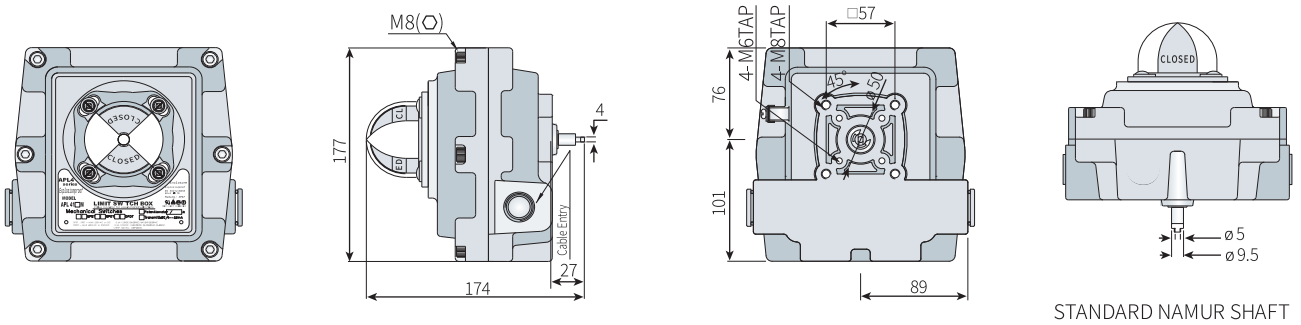

APL-5

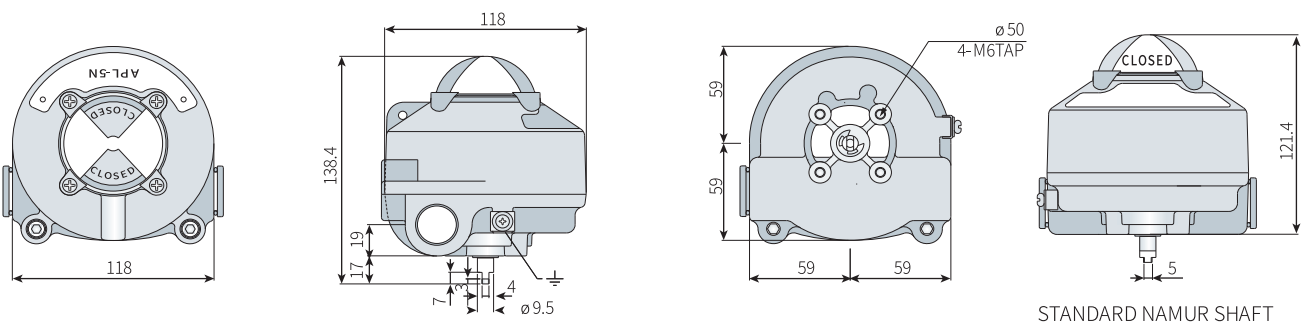

APL-7

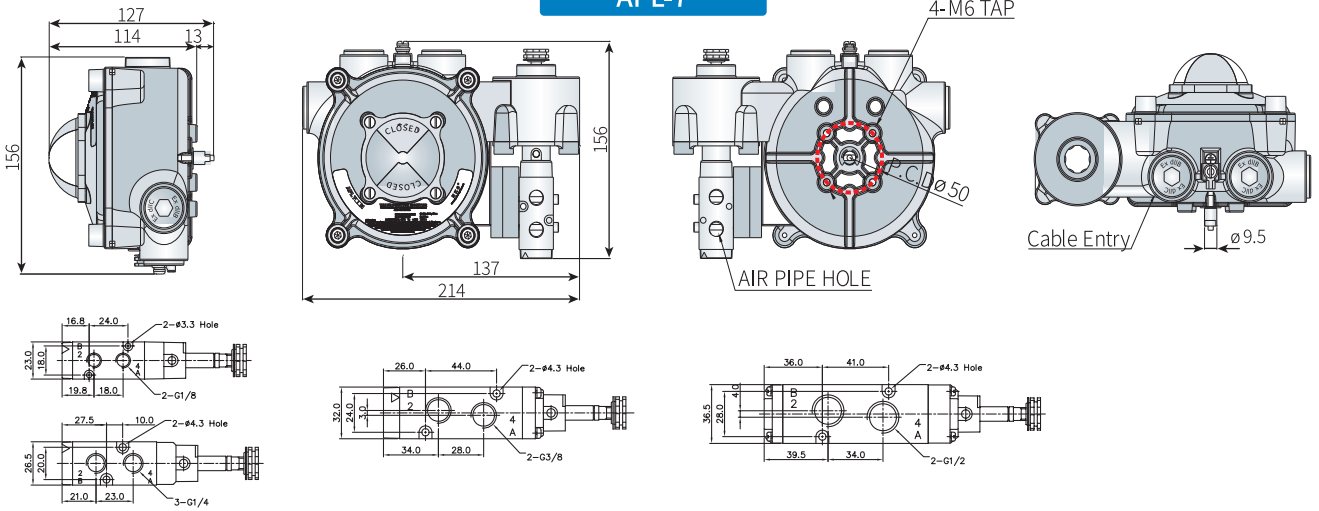

APL-8

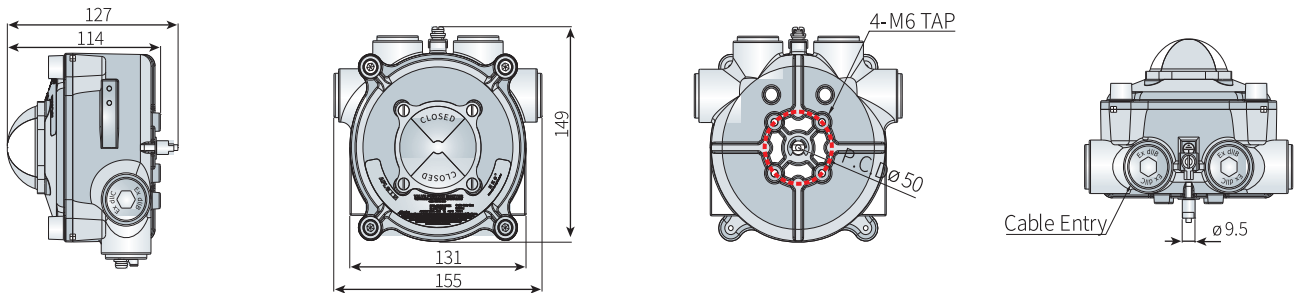

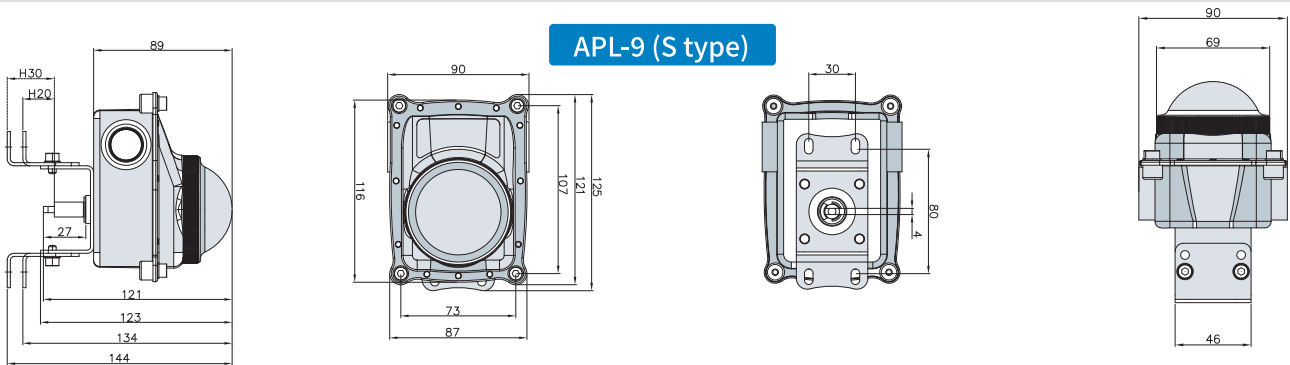

APL-9 (S type)



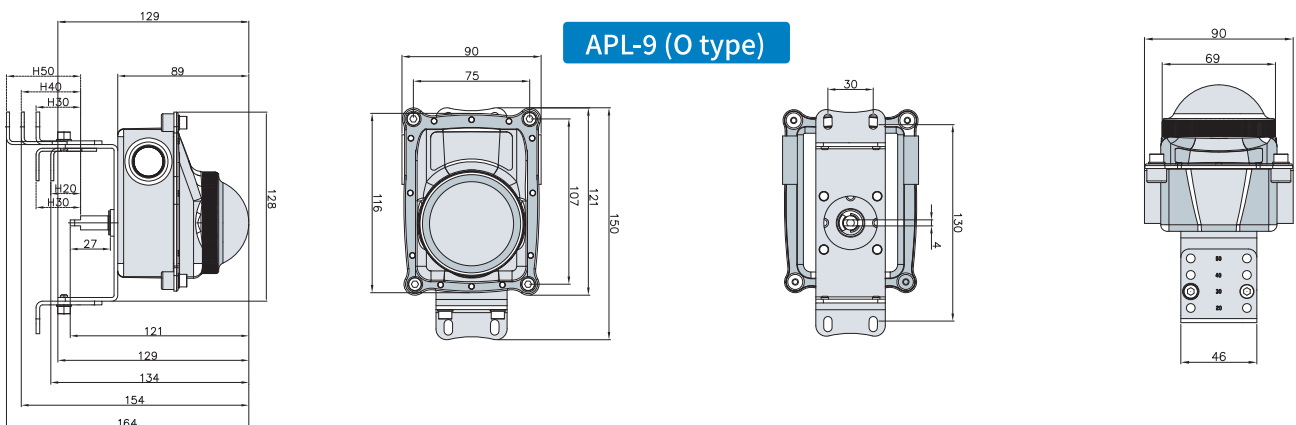

APL-9 (O type)



Switches

	Arrangement 2-SPDT (standard) 3-SPDT (except APL-2 & 9) 4-SPDT (except APL-2 & 9)	Ratings 16 A, 125/250 V ac 0.3 A, 250 V dc 0.5 A, 135 V dc 10 A, 30 V dc	Service life Min. 1,000,000 operations (mechanical) Min. 10,000 operations (electrical)	Operating frequency 120 operations / min (mechanical) 10-30 operations / min (electrical)
	Arrangement 2-DPDT (except APL-2 & 9)	Ratings 10 A, 125/250 V ac 10 A, 30 V dc 0.5 A 125 V dc 0.25 A 250 V dc	Service life Min. 1,000,000 operations (mechanical) Min. 50,000 operations (electrical)	Operating frequency 240 operations / min (mechanical) 20 operations / min (electrical)
	Arrangement 2-DPDT (except APL-2 & 9)	Ratings 20 A, 125/250 V ac 0.5A, 250V dc	Service life Min. 6,000 operations (electrical)	Operating frequency

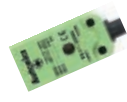

Proximity Sensors

	P&F. NJ2V3-N (intrinsically safe) Inductive proximity sensor Voltage range: 8 V dc Sensing range: 2 mm		Autonics. PS17-5DNU Inductive proximity sensor Voltage range: 10-30 V dc Sensing range: 5 mm (except APL-2 & 9)
	P&F. NBB2-V3-Z4/Z5 Inductive proximity sensor Voltage range: 5-60 V dc Sensing range: 3 mm	Other sensors NBB2-V3-E2/E3(PNP): 10-30 V dc NBB2-V3-E0(NPN): 10-30 V dc	APL-4 proximity sensors NJ2-12GM-40-E 2: 10-60 V dc NJ4-12GM-40-E 2: 10-60 V dc NBB2-12GM-40: 6-60 V dc

Reed Proximity Sensors

	2-SPST switches Contact form: NO, NC Ratings: 10 W Max. Switching voltage: 200 V dc Max. Switching current: 0.5 A Max. Breakdown voltage: 250 V dc Min. Contact resistance (initial): 0.3 Ω Max. Electrical life: 10,000,000 operations (6 V dc, 10 mA)	2-SPDT switches Contact form: NO, NC Ratings: 5 W Max. Switching voltage: 175 V dc Max. Switching current: 0.25 A Max. (option: 1.5 A Max @60 V dc Max.) Breakdown voltage: 200 V dc Min. Contact resistance (initial): 0.3 Ω Max. Electrical life: 10,000,000 operations (12 V dc, 10 mA)
---	---	--

Brackets

Shape			
Model	MBP-50 (25 x 50 H:20) MBP-100 (30 x 80 H:20) MBP-200 (30 x 80 H:30) MBP-300 (30 x 130 H:30) MBP-400 (30 x 130 H:50)	MB-P-O-1C (30 x 80 H:20) MB-P-O-1S (30 x 80 H:20) MB-P-O-2C (30 x 80 H:30) MB-P-O-2S (30 x 80 H:30)	MB-P-O-3C (30 x 130 H:30) MB-P-O-3S (30 x 130 H:30) MB-P-O-4C (30 x 130 H:50) MB-P-O-4S (30 x 130 H:50)

※The last letter of the model name: C means carbon steel plate, S means stainless steel plate.

APL - 3 10 N

Model (Enclosure shape)

- 2: Standard (IP67, NEMA 4, 4X)
- 3: Standard (IP67, NEMA 4, 4X)
- 4: Flameproof (Ex db IIB T5, Cl.I, Div.1, Gr.C,D, IP67, NEMA 4X, 6)
- 5: Flameproof (Ex db IIC T6, Cl.1, Div.1, Gr.B,C,D, IP67, Cl.II, Div.1, Gr.E,F,G, Cl.III, NEMA 4X, 6)
Dust ignition proof (Ex tb IIC T85°C)
Intrinsic safety (Ex ia IIC T6) with proximity sensor (option); APL-520 only
- 7: Flame proof (Ex db IIC T5) with solenoid valve
- 8: Flame proof (Ex db IIC T6) with 4 cable entries
- 9: 304 Stainless steel (IP67)

Switch type

Mechanical switch

- 10 2-SPDT
- 11 3-SPDT
- 12 4-SPDT
- 13 2-SPST
- 14 2-DPDT
- 15 2-SPDT + Potentiometer
- 16 2-SPDT + Signal unit(4-20 mA)
- H1 2-SPDT (-50 to +60°C) Honeywell 11SX22-T (APL-5 only) [CSA]
- H2 2-SPDT (-50 to +60°C) Honeywell Gold plated 12SX1-T (APL-5 only) [CSA]
- H3 2-SPDT (-50 to +60°C) Honeywell Gold plated 13SX21-T (APL-5 only) [CSA]
- H4 4-SPDT (-50 to +60°C) Honeywell 11SX22-T (APL-5 only) [CSA]
- H5 4-SPDT (-50 to +60°C) Honeywell Gold plated 12SX1-T (APL-5 only) [CSA]
- H6 4-SPDT (-50 to +60°C) Honeywell Gold plated 13SX21-T (APL-5 only) [CSA]

Proximity sensor

- 20 P&F. NJ2-V3-N
- 21 Autonics. PS17-5DNU
- 22 P&F. NJ4-12GM-N
- 23 P&F. NBB2-V3
- 25 P&F. NJ2-V3-N + Potentiometer
- 26 P&F. NJ2-V3-N + CPT(4-20 mA)

Reed type proximity sensor

- 30 MS-B 301 / MK21-85 (CSA)
- 31 MK21-66 (CSA)
- 32 MK21-90 (CSA)
- 34 APH-634W
- 35 APH-933W
- 36 APH-27103

Enclosure Material

- N : Non-ferrous metal
- S : Stainless steel (304, 316, 316L)
[APL-5, 8 & 9 only]

Declutchable Gear Override HGO Series

Features

- In case of compressed supply air failure, the HGO Series enables manual operation of the pneumatic actuator
- The HGO Series is typically installed between a pneumatic actuator and quarter-turn valves, including ball, butterfly, and plug valves
- To rapidly discharge the residual air used in the actuator, a block-bleed valve is employed
- The self-lubricating worn shaft guide ensures high reliability and stability of the product



Certificates and approvals

- EAC



Specification

Standard Specification

Enclosure			
Travel angle			
Max. output torque	HGO-010: 120 Nm	Weight	HGO-010: 3.2 kg
	HGO-050: 500 Nm		HGO-050: 5.1 kg
	HGO-080: 800 Nm		HGO-080: 16.1 kg
	HGO-150: 1,500 Nm		HGO-150: 42.8 kg
Ambient temperature			
Base flange (ISO 5211)	HGO-010: F05, F07 (17 mm Star)	Top flange (ISO 5211)	HGO-010: F05, F07 (11, 14, 17 mm Star)
	HGO-050: F10, F12 (22 mm Star)		HGO-050: F07, F10 (17, 22 mm Star)
	HGO-080: F10, F12 (27 mm Star)		HGO-080: F10, F12 (22, 27 mm Star)
	HGO-150: F14 (36 mm Star) / F12 (36 mm Star)		HGO-150: F10, F14 (27, 36 mm Star) / F12 (27, 36 mm Star)
Coating (color)			

Optional Specification

Ambient temperature	LT Low temperature: -40 to +80 °C
	HT High temperature: -20 to +150 °C
Coating (color)	Other colors , Nano coating (for corrosive environment)

Dimensional Drawing

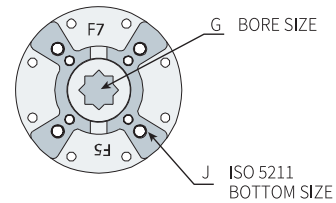
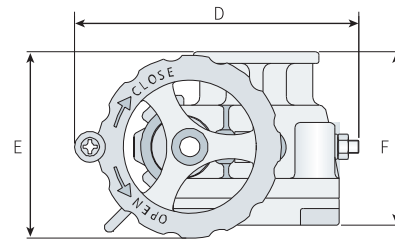
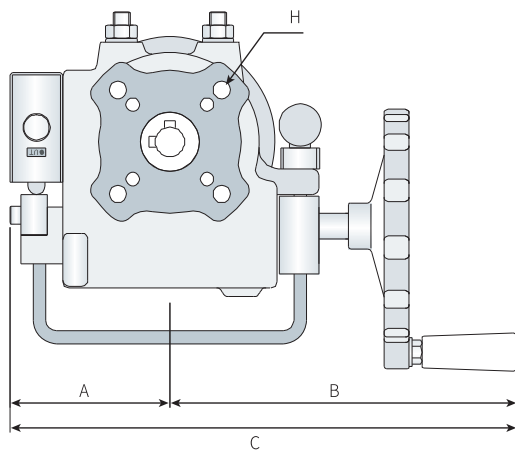

Dimension

Model	unit	A	B	C	D	E	F	G	H/J	Weight	Max. Torque	Applicable Actuators
HGO-010A	mm	81	159	240	158	112	104	14	F05, F07	3.2 kg	12 kgf.m	HP-035 to HP-075
	inch	3.2	6.3	9.5	6.2	4.4	4.1	0.6			1,040 lb.in	
HGO-050C	mm	104	212	316	229	469	148	22	F10, F12	16.1 kg	50 kgf.m	HP-088 to HP-125
	inch	4.1	8.4	12.4	9.0	6.7	5.8	0.87			4,340 lb.in	
HGO-080C	mm	104	220	324	261	204	154	27	F10, F12	17.1 kg	80 kgf.m	HP-125 to HP-160
	inch	4.1	8.7	12.8	10.3	8.0	6.1	1.1			6,943 lb.in	
HGO-150C	mm	128	274	402	346	300	190	36	F12 or F14	42.8 kg	150 kgf.m	HP-160 to HP-200
	inch	5.0	10.8	15.8	16.6	11.8	6.3	1.4			13,019 lb.in	

※ The last letter 'A' in the model name refers to aluminum, while the letter 'C' refers to cast iron

Valve Automation Leader HKC

