

SBU ADVANCED



Smart Valve Monitoring via Bluetooth interface.
Continuous monitoring of the main functions of the valve and actuator.

TECHNICAL FEATURES

Case:	Aluminium (powder coated)
Connection:	Spring Type Terminal
Protection class:	IP 68 according to EN 60529
Temperature range:	-20°C to +70°C
Adjustment range:	0 to 240°
Power supply:	24VDC ±10%
Screws:	Stainless steel
Output signals:	Digital outputs 24 VDC
Solenoid valve:	24 VDC, max 5W
Power consumption:	max. 200mA
Interface	Bluetooth
Optional version:	ATEX 2D For gate valves and linear actuators

GENERAL INFORMATION

- Direct mounting according to VDI/VDE 3845.
- Microcontroller integrated

MAIN ADVANTAGES

- Continuous monitoring of the valve operation
- Diagnosis and recording of the operation
- Recording and reporting of malfunctions
- Ambient temperature monitoring
- The collected data are provided via Bluetooth (BLE 4.0)
- App "EBRO Connect" for mobile devices
- Digital inputs and outputs
- Non-contact end position detection (Hall sensor)



Visit our homepage for further information.



A microcontroller monitors the valve position contactlessly using a Hall sensor. Additionally, the main functions of valve and actuator are monitored continuously.

SBU ADVANCED

MAIN DIMENSIONS

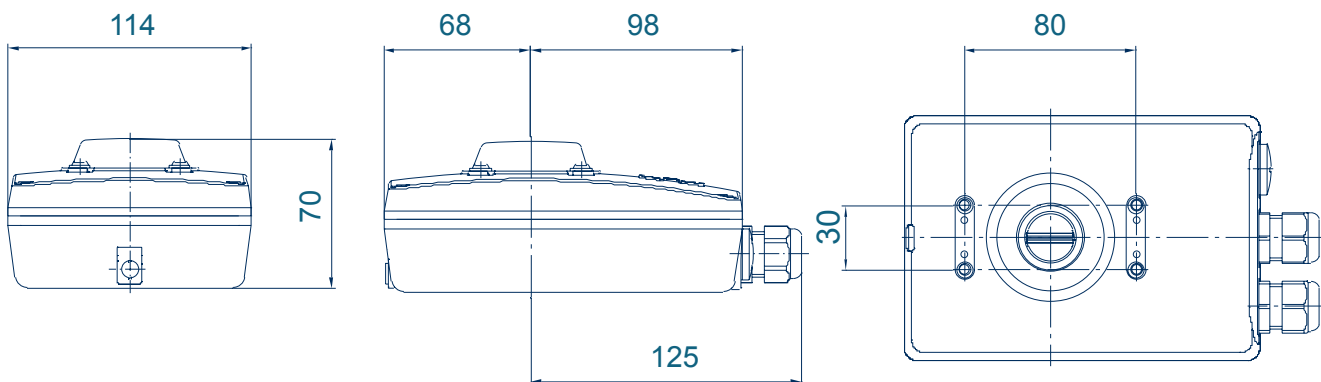

All dimensions in mm

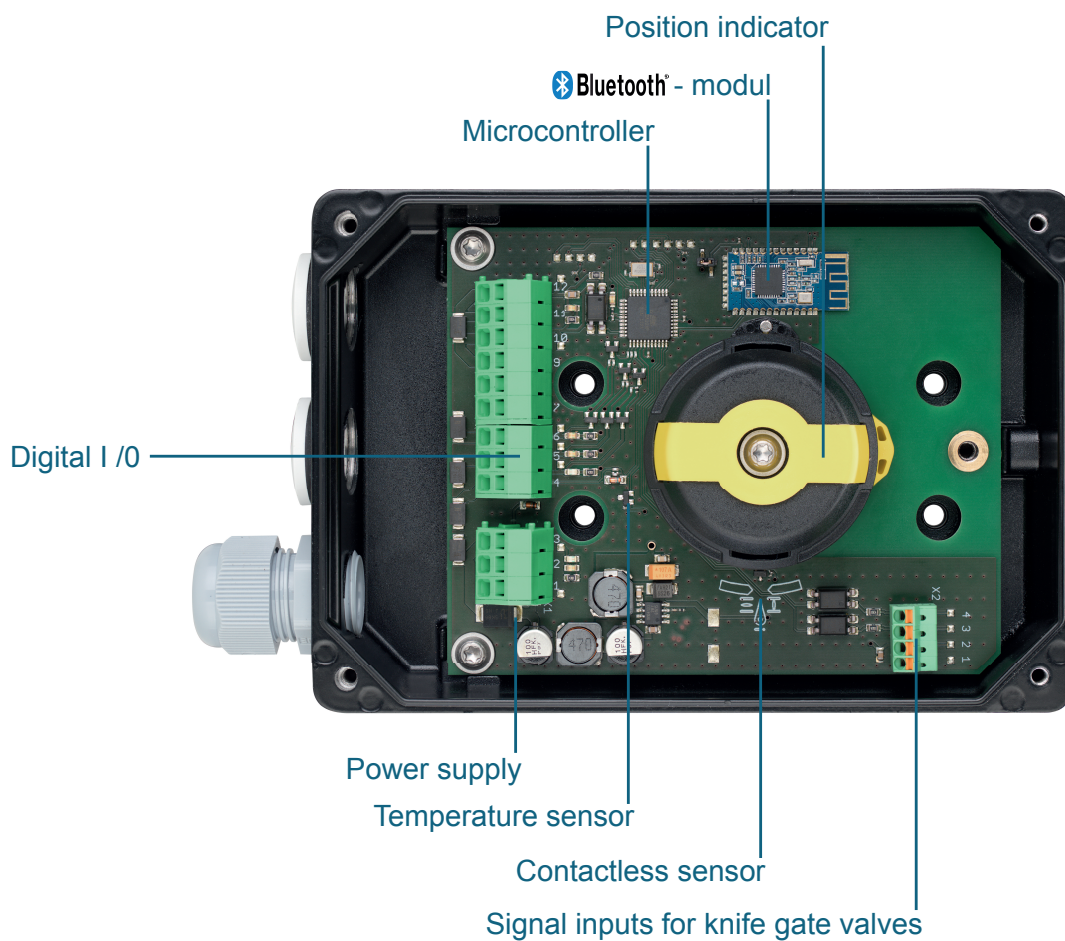

Subject to change without notice